



NCAR

NSF / NCAR C-130

INVESTIGATOR'S HANDBOOK



Research Aviation Facility, Earth Observing Laboratory
National Center for Atmospheric Research
Boulder, Colorado, USA

Summary of Revisions

Revision Date	Summary	Affected Page(s)
04/18/2008	Conversion from Draft to Original document format	All
06/30/2022	Contacts and Broken Links. Update to Chapter 3. (LL, CW, JC)	Many

Table of Contents

INVESTIGATOR'S HANDBOOK	1
Summary of Revisions.....	2
Table of Contents	3
Key Personnel Contact Information at NCAR/EOL	5
List of Acronyms/Definitions	6
Chapter 1 Requesting the Aircraft and Instrumentation	10
1.1 Aircraft Requests.....	10
1.2 Project Support Services.....	10
Chapter 2 Basic Specifications	13
2.1 General View (external diagrams)	13
2.2 Cabin Layout	15
2.3 Loading Ramp & Door	15
2.4 Weight & Balance (weight, fuel, payload).....	16
2.5 Cabin Pressurization.....	17
2.6 Communications & Navigation	17
Chapter 3 Research Systems Description	22
3.1 Structural Modifications	22
3.2 Research Power System capabilities	24
3.3 Data Acquisition System & Display.....	25
3.4 Satellite Data Communication Link.....	27
3.5 Ground Support Computing.....	28
3.6 Data Products	28
Chapter 4 Performance	29
Chapter 5 Flight Operations	34
5.1 Aircraft Certification Overview (public).....	34
5.2 Crew Duty Limitations.....	34
5.3 Operating Policies for Flight Planning.....	35
5.4 Fitness Requirements.....	38
5.5 Emergency Procedures.....	39
5.6 Safety Training.....	39
5.7 Security	39
Chapter 6 Investigator Equipment Packages	40
6.1 Design Criteria	41
6.2 Structural Considerations.....	42
6.3 Electrical Considerations.....	53
6.4 Data Recoding & Interface Capabilities	56
6.5 Airflow Modeling Data & Availability.....	56
Chapter 7 NCAR/EOL Standard Instrumentation Overview	58
Chapter 8 Feasibility & Instrumentation Integration Procedures	59
8.1 Instrument Certification and Approval.....	59
8.2 Project lifecycle reviews and payload certification	60
8.3 New Instruments.....	61
8.4 Instruments Previously Flown.....	61

8.5 Feasibility Review of Proposed Campaigns	62
8.6 Flight Test Opportunities.....	63
Chapter 9 Insurance – Liability Coverage, Bodily Injury, Property Damage	64
Appendix A Medical Information for Airborne Research.....	65
Appendix B Approved Wiring and Non-Wire Materials	66

Key Personnel Contact Information at NCAR/EOL

Earth Observing Laboratory (EOL) Directorate

Dr. Scott McIntosh	Laboratory Director	303-497-1544	mScott@ucar.edu
Brigitte Baeuerle	Assistant Director	303-497-2061	baeuerle@ucar.edu

Research Aviation Facility (RAF)

Dr. Lou Lussier	Manager	303-497-1080	lussier@ucar.edu
Joseph "Scotty" McClain	Chief of Flight Operations and Maintenance	303-497-1081	mccclain@ucar.edu
Dr. Julie Haggerty	RAF Science and Instrumentation Group Lead	303-497-1090	haggerty@ucar.edu
Rani Bartlett	Aeronautical Engineer	303-497-1020	rbartlett@ucar.edu
Kurt Zrubek	Certification, Electrical and Instrumentation Engineer	303-497-1086	kurt@ucar.edu

Design and Fabrication Services (DFS)

Jim Ranson	Manager	303-497-8781	jranson@ucar.edu
------------	---------	--------------	--

List of Acronyms/Definitions

ACAS	Aircraft Collision Avoidance System
ACP	Audio Control Panel
A/D	Analog to Digital
ADADS	Aircraft Data Acquisition and Display System
ADF	Automatic Direction Finder
ADS	Airborne or Aircraft Data System
AEROS	Airborne Environment Research Observing System
AFIS	Airborne Flight Information System
AGL	Above Ground Level
ALT	Altitude
ANSI	American National Standards Institute
APA	Airport Pressure Altitude
APU	Auxiliary Power Unit
ARINC	Air Radio Incorporated
ASCII	American Standard Code for Information Interchanges
ATC	Air Traffic Control
ATCRBS	Air Traffic Control Radar Beacon System
ATIS	Automatic Terminal Information Service
BL	Buttline (in inches)
CDS	Computing Data and Software
CFIT	Controlled Flight Into Terrain
CG	Center of Gravity
COTS	Commercially Available Off The Shelf
CRT	Cathode Ray Tube
CW	Continuous Wave
DER	Designated Engineering Representative
DFS	Design and Fabrication Services
DME	Distance Measuring Equipment
DMT	Droplet Measurement Technologies, Inc.
DOD	Department of Defense
DSM	Data Sampling Module

EDO	Extended Data Out
EIA	Electronics Industry Association
ELT	Emergency Locator Transmitter
EOL	Earth Observing Laboratory
FAA	Federal Aviation Administration
FAC	Facilities Allocation Committee
FAR	Federal Aviation Regulation
FIFO	First In First Out
FMCS	Flight Management Control System
FMS	Flight Management System
FPS	Field Project Services
GAC	Gulfstream Aerospace Corporation
GNSSU	Global Navigation System Sensor Unit
GPS	Global Position Sensor, Global Positioning System
GPWS	Ground Proximity Warning System
GS	Glide Slope
GTW	Gross Takeoff Weight
GV	Gulfstream V Aircraft
GVFS	GV Fuselage Station
HDLC	High Level Data Link Control
HF	High Frequency Communications
HIAPER	High altitude Instrumented Airborne Platform for Environmental Research
HSD	High Speed Data
ICP	Interphone Control Panel
ICS	Intercommunications System
IDG	Integrated Drive Generator
ILS	Instrument Landing System
I/O	Input / Output
IRIG	Inter Range Communication Group
IRS	Inertial Reference System
IRU	Inertial Reference Unit
ISA	International Standard Atmosphere

KCAS	Knots Calibrated Air Speed
KTAS	Knots True Air Speed
LAN	Local Area Network
LAOF	Lower Atmospheric Observing Facilities
LBL	Left Buttline (in inches)
LEO	Low Earth Orbiting
LOC	Localizers
LNAV	Lateral Navigation Localizers
MADC	Micro Air Data Computers
MMO	Maximum Operating Mach Number
MNP	Minimum Navigation Performance
MPDB	Main Power Distribution Box
MSL	Standard Atmosphere
NACA	National Advisory Committee on Aeronautics
NATO	North Atlantic Treaty Organization
NCAR	National Center for Atmospheric Research
NEMA	National Electrical Manufacturers Association
netCDF	Network Compact Data Format
NM	Nautical Mile
NEXRAD	Next Generation Radar
NSF	National Science Foundation
NTP	Network Time Protocol
PCI	Peripheral Component Interconnect
PI	Principal Investigator
PIC	Pilot In Command
PMS	Particle Measuring System
PPS	Pulse Per Second
PSI	Passenger Service Units
RAD ALT	Radio Altimeter
RAF	Research Aviation Facility
RBL	Right Buttline (in inches)
RDP	Research Data Program

RNAV	Area Navigation
RVSM	Reduced Vertical Separation Minimum
SATCOM	Communications Satellite
SIGMETS	Significant Meteorological Conditions
SOD	Scientific Overview Document
SPDB	Secondary Power Distribution Box
SPDDB	Secondary Power Distribution Drop Box
SQL	Structured Query Language
SSDB	Secondary Signal Distribution Box
TAS	True Airspeed
TCAS	Traffic Collision Avoidance System
TWIP	Terminal Weather Information for Pilots
UDP/IP	User Datagram Protocol/Internet Protocol
UPS	Uninterruptible Power Supply
USAF	United States Air Force
VDC	Voltage From Direct Current
VHFNAV	Very High Frequency Navigation System
VHF	Very High Frequency Communications
VME	VersaModule Eurocard Bus
VNAV	Vertical Navigation
VOR	Omnidirectional Range
VSR	Stall Reference Speed
WL	Waterline (in inches)
WOW	Weight-On-Wheels

C-130 Investigators Handbook

Chapter 1 Requesting the Aircraft and Instrumentation

1.1 Aircraft Requests

EOL manages and operates the majority of NSF's Lower Atmospheric Observing Facilities (LAOF) and makes them available on a competitive basis to qualified researchers from universities, NCAR, and other government agencies. Deployment decisions for each facility are driven by the scientific merit of the proposed use, the capabilities of a specific facility to carry out the proposed observations, and availability of the facility for the requested time period. The NSF/NCAR C-130 is part of the LAOF group. Correspondingly, proposed usages of the aircraft for research are eligible for NSF deployment pool funding support.

Procedures for requesting use of the C-130 and other NSF-supported facilities are outlined in the NSF Lower Atmospheric Observing Facilities User Guide. This document may be directly retrieved on-line at <https://www.eol.ucar.edu/request-lower-atmosphere-observing-facilities>.

1.2 Project Support Services

Investigators interested in requesting usage of the NSF/NCAR GV for support of their research program can expect comprehensive, end-to-end field project support from EOL. EOL personnel are available to provide assistance at all stages of a project's lifecycle, from the early planning phase, through the deployment period, and extending out beyond the final data processing and distribution phase.

The sections below provide more detailed information about the specific types of programmatic support provided by EOL staff members.

1.2.1 Basic and Specialized Research Instrumentation

Several basic and specialized instrument packages can be made available to C-130 users upon request. Standard instruments available on the aircraft are described in the [RAF Standard Instrumentation Manual](#) document. EOL personnel assume responsibility for installing and maintaining these instruments. In addition, EOL staff members will help investigators with the installation of user-supplied instrumentation on the C-130. All user-furnished equipment will need to comply with specified EOL design and interface requirements. Requirements for the integration of investigator equipment packages are detailed in Chapter 5 of this handbook.

RAF personnel supervise the installation of user-supplied equipment on the C-130 in order to ensure compatibility with existing aircraft operations and instrumentation systems and to ensure that all safety of flight and engineering requirements are met.

EOL/RAF staff members provide in-flight oversight of equipment operation. However, this does not normally include the operation of user-supplied instrumentation. If investigators will require EOL personnel to provide in-flight sensor operation assistance, this requirement must be identified on the aircraft request form available from EOL the Project Request Online (PRESTO; <https://presto.xsede.org/login>).

1.2.2 Engineering Support

EOL can provide aeronautical, mechanical, and electrical engineering support services to investigators in order to ensure that user-supplied equipment meets all design and fabrication requirements set forth for the C-130 (see Chapter 6 of this handbook). Requests for such assistance must be clearly identified on the aircraft request form and should also be discussed with EOL personnel during the pre-project planning phase.

Specific questions about aeronautical, mechanical, and electrical engineering support services available within EOL should be addressed to RAF Aeronautical Engineering, the EOL/DFS Manager, and the RAF Electrical Engineer respectively.

1.2.3 Operational and Scientific Support

A RAF Project Manager is assigned to each C-130 program to serve as a point of contact for platform investigators and to work with them to plan the most effective scientific experiment possible. Based on his/her knowledge of the program's scientific requirements, the Project Manager may assist in defining particular sensors for the instrumentation package, the design of flight profiles, or the most applicable data processing techniques. At a minimum, EOL staff members are normally responsible for project planning (in close cooperation with project investigators), conduct of project operations, quality control oversight for EOL-supported sensors, oversight of data system performance, EOL data processing, and final EOL data delivery to the user. Delivery of user (non-EOL) data is normally not a responsibility of EOL personnel. More in-depth scientific participation is dependent on the specific needs and wishes of the requesting scientists and should be discussed with EOL scientists at the time the aircraft request form is submitted. For general information about RAF project management services, investigators should contact the Airborne Project Office (APO) at raf-pm@ucar.edu.

Project principal investigators are required to guide and participate in the in-flight conduct of research. This may be done through delegation to another qualified member of the investigator's group or through delegation to a qualified member of the RAF support team. In all such cases, it is necessary for the principal investigator and the investigator's group to visit the RAF prior to the start of the field program to receive orientation and training in the safe operations of instrumentation and any associated data recording equipment. Project investigators normally participate in the instrumentation flight tests, which are conducted prior to the scientific field phase of the program.

A mission scientist is normally required on the C-130 to perform in-flight mission coordination and to handle communications with pilots, scientific crew members, and ground support personnel. Because the mission scientist communicates directly with the pilots during flight operations, specialized training in cockpit and flight procedures/protocol is required. The RAF pilots will provide this training to project investigators who wish to serve as mission scientists, provided there are no impediments (e.g., language barriers) to the investigator being able to communicate effectively. Alternatively, EOL can supply a trained mission scientist. It should be noted that mission scientists are normally not in a position to operate cabin instrumentation during flight. For especially complex missions or missions flying in close proximity to extreme weather, RAF will have a Mission Coordinator onboard. The Mission Coordinator is a specially trained member of the RAF.

The RAF pilots work with investigators and with the assigned RAF C-130 Project Manager to plan missions, obtain air traffic control flight clearances, and to address special requests pertaining to flight operations. Requests for diplomatic clearances, which are required when operating in most foreign countries, are initiated by EOL personnel after project approval.

Chapter 2 Basic Specifications

2.1 General View (external diagrams)

The Lockheed C-130Q Hercules is a four-engine, medium-size utility aircraft which has proven to be one of the most well-known and versatile aircraft ever built. For reference purposes, the aircraft is similar to a standard model C-130H except for electrical and air-conditioning modifications. It has twice the heating/cooling capacity of a standard C-130H and ultimately more than twice the electrical power. (At present 40 kVA are available for research.) The aircraft is an all-metal, high-wing monoplane, powered by four Allison T-56-A-15 turbo-prop engines. It is equipped with dual-wheel, tricycle landing gear with the main gear wheels arranged in tandem and the nose gear arranged side-by-side. N130AR was placed in service (by the USN) in 1985 and is the youngest aircraft in the NSF/NCAR/RAF fleet.



Figure 2.1 The NSF/NCAR C-130Q (N130AR) aircraft.

The performance figures for the NSF/NCAR C-130Q Hercules aircraft are summarized in Table 1 below. Chapter 4 on platform performance provides detailed information for scientists to outline realistic, research flight plans. During a research program, the NCAR pilots, who are responsible for the detailed planning of specific flight profiles, will work closely with the requestor.

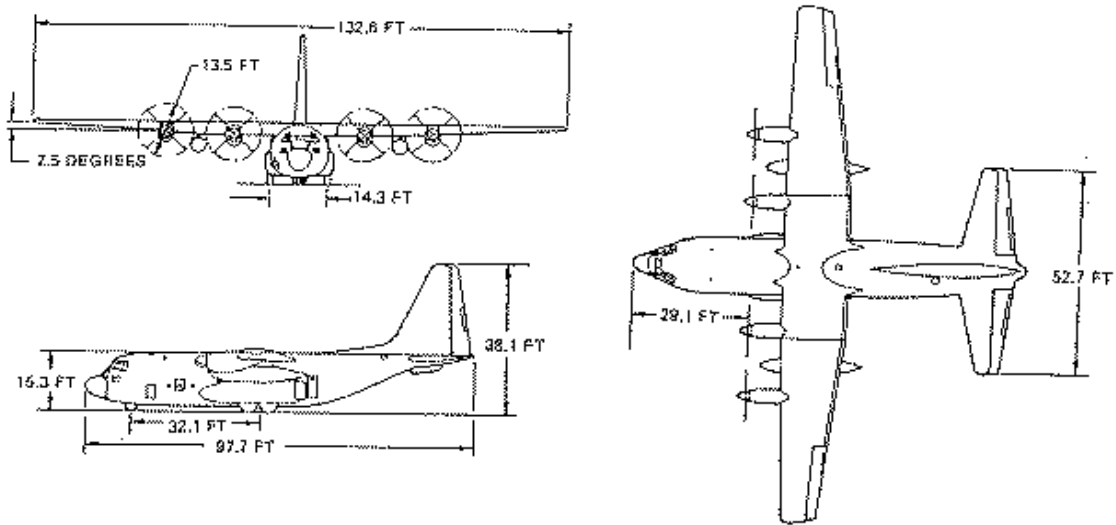

Figure 2.2 Three views of the C-130Q aircraft.

The interior of the Hercules includes a flight deck and a "payload" cabin compartment. During flights, the flight deck has a crew of three and a mission-scientist station position. This area also has two crew-rest positions which can accommodate two temporary observer stations. The aft cabin area is approximately 40 feet long, 9 feet in height, and 10 feet wide. An integral loading ramp and cargo door system is located under the tail section. Figure 2.3 shows the cross section of the fuselage. The configuration of the cabin can be changed to accommodate individual project instrumentation needs. Sectionalized seat tracks (rails) are installed to rack up instrumentation anywhere in the cabin area.

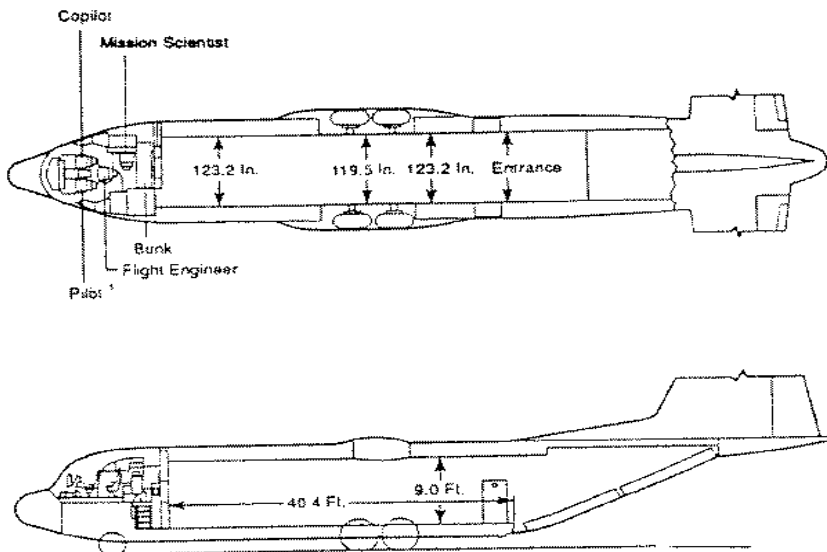

Figure 2.3 C-130Q fuselage cross section.

2.2 Cabin Layout

The basic configuration of the C-130 cabin appears in Figure 2.4. Key support features intended to facilitate research such as external apertures, access points to the community exhaust system, and cylinder storage areas are clearly marked. The pattern of floor hardpoints lay the framework for designing research payload layouts.

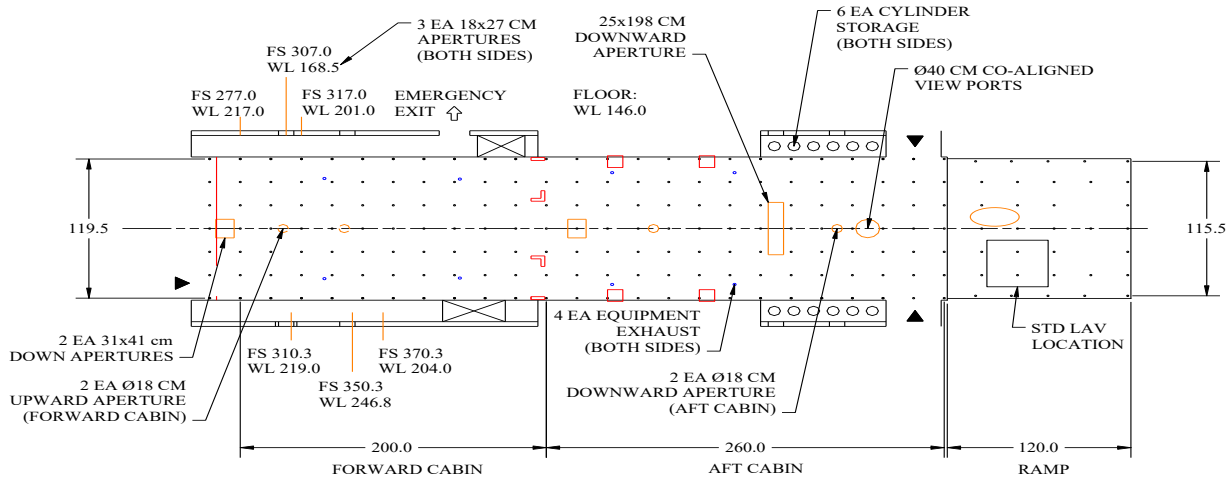

Figure 2.4 C-130 Cabin Configuration.

2.2.1 Observer positions

The maximum crew complement for the C-130 is 19, comprised of RAF flight crew, instrumentation operators, and scientific observers. The minimum flight crew is: 2 pilots; 1 flight engineer; and 1 ADS operator / load master. All crew members (research and support) must have access to approved seating for all takeoff and landing cycles. The location/layout of the seats is quite flexible and is usually driven by the need for dedicated instrument operators for some of the research instrumentation. A unique payload layout will be established for each field project depending on the specific needs of that project. Any such layout must allow adequate spacing for emergency egress from the aircraft and account for free access to certain emergency equipment. This can affect grouping of the seats at certain locations. All seat locations have an area under the seat for personal storage and are equipped with access to the ICS communications system as well as a source of emergency oxygen.

2.3 Loading Ramp & Door

The aircraft may be operated un-pressurized with the ramp lowered and locked in the horizontal position. The ramp is heavily structured, and apparatus could be extended to overhang the ramp's lip after takeoff. Further aft, the upper cargo door, which swings up, can also be opened and locked in place in flight either by itself or in combination with the ramp. The ramp/door combination provides the capability to drop large objects

from the aircraft either by parachute extraction or by free fall in combination with a standard C-130 cargo-handling system. (The cargo-handling system is not available on this aircraft in its present configuration.)

2.4 Weight & Balance (weight, fuel, payload)

Research flight operations and payload options are governed by the platform specific load limitations summarized in Table 2.4. Payloads can be expanded beyond the full fuel limit listed by trading in-flight endurance (reduced fuel load) for added instrumentation at a rate of roughly 5,000 lb per hour of fuel up to the max zero fuel weight limit. NCAR determines the aircraft's research zero fuel weight and center of gravity (either by weighing the aircraft or by numerical computation of the configuration) prior to each field deployment to ensure the aircraft remains within the approved C-130 flight envelope. Note that, regardless of the weight limitations or cabin configuration, the maximum crew complement (OPS & Research) that can be carried on the C-130 is 19.

Table 2.4 Load Limitations Lockheed Model C-130Q Hercules Registration Number N130AR		
Category	Weight	
Maximum gross weight for takeoff	155,000 lb	
Maximum gross weight for landing	130,000 lb	
Maximum zero fuel weight	105,000 lb	
Operating weight (crew of 3, no fuel, basic instruments)	82,000 lb	
Fuel capacity	9,500 gallons (62,000 lb)	
Payload (crew and all equipment)	23,000 lb	13,000 lb (with full fuel)

1. **Maximum gross weight:** Sometimes referred to as the "all-up gross weight," this is the maximum allowable weight of the aircraft, crew, passengers, fuel, and equipment. It also is referred to as maximum ramp weight.
2. **Payload:** Difference between the empty weight and the maximum zero-fuel weight. Crew and baggage are included in this figure.
3. **Maximum zero-fuel weight:** This is the maximum allowable weight of the aircraft plus complete payload, including all crew members, baggage, spare parts, etc.

Fuel is not included in this figure. Any weight added beyond the maximum zero fuel weight must be fuel.

4. **Maximum landing weight:** The maximum weight at which a normal landing can be made. Any landing executed when the aircraft weight exceeds this figure would be an emergency situation. (The C-130 aircraft, with maximum gross weight at take off, requires approximately 5 hours of flying time to reach the maximum landing weight.)

An accurate estimate of the weight and size of user equipment to be installed on the aircraft is a critically-important requirement in the initial request for aviation support. Estimated weights and sizes also must include any support equipment (e.g. gas cylinders, spares, tools, supplies) which are to be carried on the aircraft during ferry or research flights. RAF's feasibility evaluation of a program is based on this information. Any changes to the original proposal will require a reevaluation of the proposed flight profiles, and possibly require changes in the cabin layout, to comply with aircraft balance requirements.

2.5 Cabin Pressurization

Under most circumstances the aircraft will be operated under full cabin pressurization. Cabin pressure altitudes are maintained at 5000 ft equivalent or less up to a maximum research altitude of 25,000 ft. The pressure relief valve setting is 7.8 psi. The aircraft is equipped with an emergency release system for a rapid exchange of the entire cabin volume in case of smoke or the release of and toxic material.

2.6 Communications & Navigation

2.6.1 Integrated Flight Management System (FMS)

The C-130 is equipped with a Global Wulfsberg GNS-XLS Flight Management System with inputs from inertial reference systems (IRS), a built in GPS receiver and VOR/DME system to compute present position. The FMS provides interfaces to aircraft flight direction instrumentation such as the auto-pilot and horizontal situation indicator. The CDU provides waypoint and navigation information to the pilots.

2.6.2 Communications Systems

The aircraft is equipped with the following communications equipment. Frequency ranges are provided so that investigators can engineer their equipment to utilize frequencies other than those specified for various C-130 systems in order to prevent interference with aircraft equipment.

High Frequency (HF) Communications: Dual HF transceivers provide 99 user-programmable preset channels and 280,000 discrete operating frequencies covering the 2.0000 – 29.9999 MHz range in 100 Hz increments. Wire antennae (2) run from the top of the tail to the top of the forward fuselage.

Very High Frequency (VHF) Communications: Dual VHF communications transceivers provide AM voice communications in the frequency range of 118.0 – 136.975 MHz in 8.33 kHz increments for a total of 1360 separate channels. The use of these frequencies for scientific purposes (ie. Other than routine contact with the Federal Aviation Administration [FAA] requires that NCAR apply for authorization in advance of the project. It is important that project specific communications needs be clearly defined by the investigators in the C-130 Facility Request Form.

Intercommunications System (ICS):

The Intercommunications System (ICS) installed in the C-130 consists of twenty-five main cabin stations, two paratroop, two cockpit bunk, one PI station, one flight instructor and one FE and two pilot stations. Main cabin user ICS stations provide 5-channel selections with volume control and call button.

User Station Locations

Dual ICS Stations
FS 390 left and right
FS 510 left and right
FS 596 left and right
FS 652 left and right
Cockpit Bunk FS 250 right
Rack
Triple ICS Station
FS 332 left and right
Single ICS Station
FS 850 right

Crew Station Locations

Pilots Pedestal
Copilots Pedestal
Flight Engineer, Overhead
Flight Instructor Left
Navigators Console (PI Station)
Systems Operators Console (SYSOP) ADS
Left Paratroop Door
Right Paratroop Door

Normal ICS Operation

Normal communications are typically station to station via one of the selected channels.

Other IS Operation

User stations consist of channels A, B, C, D, & Local. Channels A, B, C, & D allow communication between all 25 Stations on each of the channels. The Local channel allows for communication between stations which are grouped together in groups of 2 and 3, dual or triple ICS stations. The PI station and the RAF tech station have access to channels A, B, C, & D as well. There is no communication access to the pilots, flight engineer, or radios from User stations. These types of communication would be coordinated through the PI or SYSOP station.

Communication over the aircraft radios is available through crew stations that have AIC ICS control and monitor panels. Note: all external communication must be coordinated with the flight crew. These stations are:

Pilots Pedestal
Copilots Pedestal
Flight Engineer, Overhead
Flight Instructor Left
Navigators Console (PI Station)
Cockpit Bunk
Systems Operators Console (SYSOP) ADS Rack
Left Paratroop Door
Right Paratroop Door

NOTE: *The ICS offer no SATCOM or IRIDIUM communications.*

Satellite Communication System (SATCOM): Iridium and Inmarsat SATCOM systems are both available on the NSF/NCAR C-130. An NAL A3LA Iridium Modem system is installed on the aircraft. The Inmarsat system is a Honeywell MCS-7163 Aero-H+/Swift 64 SATCOM system. The operating frequency range for the Iridium system is 1621.35 – 1626.5 MHz. The Inmarsat system transmits in a frequency range of 1626.5 – 1660.5 MHz and receives in a frequency range of 1530 – 1559 MHz.

Using a network of 66 low-earth orbiting (LEO) satellites, the NAL Iridium SATCOM system provides worldwide voice and data communications. RS-232 support built into the NAL cabin-mounted equipment supplies the capability for Internet dial-up connection at a maximum data transmission rate of 2.4 kilobits per second (kbps). The Honeywell Inmarsat system provides global voice, fax, and PC modem data capabilities using the Inmarsat Aero-H+ service. High speed data transfers at rates up to 128 kbps are possible using the Inmarsat Swift64 aeronautical High Speed Data (HSD) service.

Instruction in the use of the GV SATCOM systems – and additional materials describing the capabilities of the two systems – is provided to investigators by RAF personnel during preparation for aircraft field deployments. A copy of basic operating instructions for the C-130 SATCOM systems is included in Appendix B of this handbook.

Emergency Locator Transmitter (ELT): One (1) ELT System is installed in the aircraft. This system, an Artex C406-2 series ELT, is a third generation ELT that transmits at 121.5, 243.0, and 406 MHz. The system is capable of transmitting both aircraft position and aircraft identification.

2.6.3 Navigation Systems (IRS, GPS)

The aircraft is equipped with the following navigation equipment. Frequency ranges are provided so that investigators can engineer their equipment to utilize frequencies other than those specified for various C-130 systems in order to prevent interference with aircraft equipment.

VHF Navigation (VHFNAV), Instrument Landing System (ILS) and Marker Beacon: Dual VHFNAV systems provide Omni-directional Range (VOR) and ILS capabilities for the crew. The ILS is made up of the Localizer, Glide Slope, and Marker Beacon. The

ILS functions are used to provide range, azimuth, and vertical input to align the aircraft with the landing runway. Both Navigation receivers operate in a frequency range of 108.0 MHz – 117.95 MHz spaced 50 kHz apart. The Localizers (LOC) operate in the frequency range of 108 – 112 MHz, and the Glide Slope (GS) receivers operate in the frequency range of 329.3 – 335.0 MHz. These frequency ranges provide 200 VOR channels and 40 Localizer channels. The Marker Beacon antenna is optimally tuned to receive signals at 75 MHz at an input impedance of 50 ohms.

Automatic Direction Finder (ADF): Dual solid state ADFs provide bearing and audio output information that pertain to a selected ground station. The bearing and audio information are routed to the aircraft's navigation and intercommunication systems, respectively. The ADF can also be used for reception of voice or continuous wave (CW) transmissions.

Global Positioning System (GPS): Trimble Model 2100 TIO Global Navigation System Sensor Unit (GNSSUs) and a single antenna. Data from this sensor are provided to the Flight Management Control System (FMCS) for very accurate worldwide navigation capabilities. The GPS uses the Department of Defense (DOD) space-based satellite system to determine a three-dimensional aircraft position that consists of longitude, latitude, and altitude. The GNSSU is a twelve-channel GPS receiver that receives L1 transmissions (centered at 1575.42 +/-10 MHz) from the NAVSTAR GPS satellite constellation.

Distance Measuring Equipment (DME): The DME system consists of two (2) complete, independent and redundant systems. These units provide distance, time to station, ground speed, and station identification information for use by other aircraft systems. Each DME can track as many as three (3) ground stations at the same time. Channel 1 of either DME is normally paired with the on-side VOR (manually tuned), and the data are directly displayed to the flight crew. Channels 2 and 3 are used by the Flight Management System (FMS) for multi-sensor navigation and are automatically tuned. Both DME receiver functions operate in the L-band frequency range of 962 – 1213 MHz, and the transmitter functions operate in a frequency range of 1025 – 1150 MHz. The DME receiver operates 63 MHz above or below the transmitter frequency.

Air Traffic Control (ATC): Dual solid state ATC systems provide Mode A and Mode C identification replies to Air Traffic Control Radar Beacon System (ATCRBS) interrogators for tracking, identification, and altitude reporting. Mode A provides coded aircraft identification and Mode C provides aircraft altitude information. The ATC transducers receive interrogation pulses on a frequency of 1030 MHz and, in response to all valid interrogations, transmit coded replies on a frequency of 1090 MHz.

Traffic Collision Avoidance System (TCAS): One (1) TCAS 2000 (ACAS II/Change7) system and controls is installed in the GV to provide the flight crew with notifications of the presence of other transponder equipped traffic in the vicinity that may present a collision hazard. The TCAS/ACAS can track up to 50 airplanes simultaneously. The system provides aural alerts in the cockpit to the presence of

traffic and visual plots on cockpit displays of the relative location of other airplanes and visual cues for evasive maneuvers are provided to the flight crew if collision is imminent. If both converging airplanes are equipped with TCAS/ACAS and mode S transponders, the systems mutually coordinate evasive maneuvers to ensure diverging flight paths. Both TCAS antennae on the GV operate at a transmit frequency of 1030 MHz and a receive frequency of 1090 MHz. The antennae have a nominal impedance of 50 Ohms.

Enhanced Ground Proximity Warning System (GPWS): The GPWS provides wind shear detection and alerting. GPWS also provides advanced ground proximity warning with increased terrain-ahead awareness. These features help prevent accidents caused by Controlled Flight into Terrain (CFIT). The GPWS monitors the various sensor inputs for deviations that exceed predetermined parameters. The GPWS produces visual and audible warnings to notify the flight crew when any of the parameters are exceeded. The major feature of the enhanced GPWS is the incorporation of terrain awareness and display functions. The terrain awareness alerting algorithms in the GPWS computer continuously compute an advisory level and a warning level clearance envelope ahead of the aircraft. If the boundaries of these envelopes conflict with terrain elevation data in the terrain database, an alert or warning is issued.

2.6.4 Color Weather Radar

The weather avoidance radar aboard the NSF/NCAR C-130Q is a Collins WXR-700C, a C-band Doppler radar that can display radar reflectivity, areas of turbulence or a combined reflectivity-turbulence display. The Doppler display only operates at ranges less than 90 km. The radar also has a ground-mapping mode. The C-band transmit frequency of this radar provides improved storm penetration capabilities than would an X-band radar, thus improving the ability of the C-130Q to penetrate storms while avoiding the more intense storm areas. Reflectivity and velocity data can be recorded and displayed on any on-board workstation. Plans are underway for developing a combined aircraft track and radar display in real time. The main cockpit radar display is repeated in the quiet room area.

2.6.5 Radio Altimeter

The purpose of the RAD ALT system is to provide the flight crew with an accurate above ground level (AGL) altitude indication during low level flight. The range of the RAD ALT system is -20 to +2500 feet AGL. The radio altimeter antennae have an input impedance of 50 Ohms and operate within a low frequency range of 4200 – 4400 MHz.

Chapter 3 Research Systems Description

3.1 Structural Modifications

A number of structural modifications have been made to the C-130 to facilitate its use as a research platform. Some of the modifications provide mounting locations for standard EOL “in-situ” sensors that provide the meteorological context for more specialized and complex measurements made by the Users. Others are intended to support User supplied instruments – apertures for gas or aerosol sampling, large view ports for optical profiling, and infrastructure for mounting flow sensitive equipment on the wings are examples.

3.1.1 Standard Aperture Pads & Plates can be accessed in-flight

Five rectangular (18 cm by 27 cm), side looking fuselage apertures were added to the forward cabin to allow for the integration of “in-situ” sensors or gaseous and aerosol inlets. All of the apertures are located forward of the engine propeller line in order to avoid excessive turbulence and possible chemical contamination from engine exhausts. Three (3) are on the port side and two (2) are on the starboard side. All but one of these locations can be access from the cabin in-flight.

3.1.2 Special Aperture Plates – belly can’t be accessed in-flight

A variety of additional aperture pads of various sizes (ranging from 8” to 16” in diameter) and shapes are also available on the aircraft. Two are located on top of the aircraft, along the longitudinal axis. The remainder of these “special” apertures, numbering from 4 to 6 depending on the surface configuration, are located on the belly of the aircraft. All fall aft of the propeller line, but are free of engine contamination due to the high wing arrangement of the C-130. The belly mounted apertures are underneath the interior cabin flooring and are not accessible form the cabin interior in-flight. Special conduits are provided to route sample lines between inlets and rack mounted equipment.

3.1.3 Optical Ports

Several optical viewing ports were added to the airframe to allow remote sensing of the atmosphere around the aircraft. Vertically collocated 16” clear view apertures were installed in the aft cabin along the longitudinal axis of the aircraft to provide both zenith and nadir viewing angles. Transparent fused silica windows are available for EOL for these apertures. In addition, a 45” by 10” slot, oriented longitudinally, provides another downward viewing location for remotely scanning sensors from the cabin floor. A specially constructed, pressure sealed cavity allows this aperture to be used without an intervening material to secure the integrity of the pressurized cabin if necessary. There is also a 16” by 20” roughly rectangular down looking aperture in the aft loading door. This aperture is not “nadir” pointing as the door makes roughly a 30 deg angle to the direction of motion when the aircraft is secured for flight. All of these apertures can be used to mount “in-situ” sensors when not being used as optical ports.

3.1.4 Fuselage Hard-points

The standard 3-D wind measurement system is built into the nose radome and is suitable for making high rate turbulent flux measurements. Additional instrumentation hard-points have been added to the fuselage in a ring around the aft edge of the radome. These hard-points are used to mount the standard HRT temperature and HRT humidity sensors provided by EOL. The proximity of these measurements to the gust probe system allow for the calculation heat and moisture fluxes as well. One to two of these hard-points can be made available for User supplied sensors. Each hard-point is comprised of a circular hole 2.25" in diameter that feeds into the un-pressurized nose wheel bay. The hole is secured by a square cover plate with four mounting screws 2.5" apart.

3.1.5 Radiometer "Boats"

Fuselage nadir and zenith hard-points along the longitudinal axis of the aircraft are limited. In situations where multiple radiometric sensors need to be deployed, the aircraft can be equipped with additional aerodynamic fairings ("boats") that provide multiple apertures for mounting radiometric sensors. Each "boat" can accommodate up to 4 sensors, with circular apertures of 9 inches in diameter. The "boats" are mounted in such a fashion that all of the sensors will be level with respect to the aircraft airframe. This allows the User to monitor the orientation of the sensors through the research IRS system that provides pitch, roll and track angles. While the bottom "boat" is fully pressurized, the top "boat" is not. Wires and optical fibers in the top boat pass into the cabin through a centralized aperture that provides the pressure seal. The cabling must use either bulkhead connectors or potted feed throughs.

3.1.6 Wing Hard-Points & Pods

Modifications were made to the wings of the C-130 to accommodate the integration of various EOL instruments and to provide mounting locations for flow sensitive User wing stores. Small instrumentation hard-points were added to the underside of both wings. However, none of these locations are available for User equipment. Pylons were added to both wing tips. Each are capable of supporting 2 PMS style instrument canisters. In addition, two external instrument pods were attached to the wings outboard of engines #1 and #4. These pods can be used for housing a variety of EOL or User supplied sensors that can be controlled remotely. The pods have already been adapted to handle certain cloud physics instrumentation, including 3 additional PMS style instrument canisters per pod, and are also suitable for scanning radiometers or other rotating scanners because the front of the pods extend beyond the leading edges of the wings. Note that the payload weight limit for each pod is 275 kgs and that the instrumentation has to be mounted in a configuration that will keep the center-of-gravity of the pod within fairly tight limits.

3.1.7 Community Exhaust System

The aircraft has been equipped with a high volume exhaust system that vents potential contaminants generated by the research payload well aft of any gas sampling locations on the fuselage. The system is comprised of 4 two inch diameter tubes that run underneath the cabin flooring. The system is completely sealed within the cabin, with

aerodynamic venturis providing sub-ambient pressures within the tubing. User access to the exhaust system is provided through 8 ports located in the cabin floor - four ports to each side spaced uniformly along the length of the aircraft. The tubing material is chemically inert, allowing the passage of almost any gaseous exhaust.

3.1.8 Sensor Release Tubes

Two apertures have been added to the cargo loading ramp that can be used to deploy small to mid-sized scientific packages in flight without de-pressurizing the aircraft. The most common usage is for the deployment of atmospheric (dropsondes) and oceanographic (AXBT's, etc) profiling devices. Specially designed tubes are available through EOL to conduct this type of operation. Both systems can be flown simultaneously.

3.2 Research Power System capabilities

- 60 Hz 115 VAC single-phase ac power of which a nominal 35 KVA is available.
- 15 KVA 115VAC single-phase 60 Hz bridge power.¹
- 400 Hz 115 VAC single-phase ac power of which 20 KVA total is available.
- 400 Hz 115/208 VAC three-phase Wye-connection ac power of which 20 KVA is available.
- 28 VDC 5.6 kW user power is available
- 28 VDC 5.6 kW Anti-Ice total is available.

In addition, a weight-on-wheels (WOW) switch will activate 28VDC Anti-Ice after the aircraft is airborne.

Twelve 2.5 KVA frequency/power inverters are provided under the floor in the forward cable area for 115 VAC, 60 Hz power. There are six reserved for the right side of the aircraft and six reserved for the left side of the aircraft. An additional two are used for data power. The system has excellent voltage regulation and frequency stability.

The inverters shut down to prevent damage to the load, if the input voltage becomes too low (70 to 90 Vrms) or too high (125 to 132 Vrms). These inverters have an overload capability, however, the use of devices with large in-rush currents (e.g. starting a single-phase motor a vacuum pump motor) requires advance notice from the experimenter to the RAF. Special arrangements will be required to sequence the turn on to avoid power outages or damage to the converters.

Experimenters using equipment that requires AC power frequencies other than 60 or 400 Hz must provide their own converters and coordinate with RAF in advance.

¹ The Research Power Bus (R-Bus) 115VAC 60Hz system provides ~60 A of 115VAC 60Hz bridge power for 500 msec for the right side power and ~60A of 115VAC 60Hz bridge for 500 msec for the left side power for aircraft generator switching brownouts.

3.3 Data Acquisition System & Display

All of the data provided by the suite of standard C-130 sensors are recorded on a single, centralized data station located in the cabin of the aircraft. Data from User supplied instrumentation can be included in this common data record upon request. A series of remote displays are distributed around the cabin to allow real time access to the data. The data station is manned by an RAF staff member on all research flights who serves as the dedicated operator of the system and as the facility designated "load-master" in charge of all crew activities in the main cabin.

3.3.1 Data Acquisition System Overview

The C-130 aircraft data system (ADS3) is a modular system that utilizes data sampling modules (DSMs) in the cabin, the nose, the baggage compartment, and the wingpods (as needed). This distributed modular concept allows for straight forward expansion and for ease of installation. It also minimizes the amount of wiring required between instrumentation and the DSMs by keeping the DSM as close as possible to the installed sensors. Data from the DSMs are sent to the ADS3 server over the aircraft data acquisition network.

It was a principal design goal of ADS3 that the size of the new DSM be smaller than the older generation 11-slot VME chassis utilized for the ADS-II version of the system. To achieve this goal, the ADS3 DSM utilizes an industry standard architecture with a large selection of commercially available off-the-shelf (COTS) hardware. This design approach enables the ADS3 to accommodate a wide variety of instrumentation and will also make possible the addition of new instrument interfaces in the future without the need to always develop custom printed circuit boards. The PC-104 architecture was selected for the ADS3 due to the advantages of its smaller size and the greater availability of suitable COTS instrument interfaces. The standard PC-104 architecture utilizes the ISA 16-bit data bus, with maximum word transfers typically less than 10MHz. The PC-104 (ISA bus) is the ADS3 standard interface.

3.3.2 Data Interfaces

Analog inputs: Analog signals are connected to DSMs using twin-ax cables and routed to internal differential input amplifiers and an analog to digital converter. Each analog channel is calibrated via precision voltage sources as part of standard calibration procedures. Per-channel software selectable analog sample rates are 10, 100, and 1000 Hz.

A DSM provides analog-to-digital (A/D) conversion with 16-bit resolution, 14-bit effective number of bits (ENOB) performance, and +/-10mV static accuracy over temperature for up to +/-10V full scale range. Channels are sampled sequentially through a MUX input that has 10us dwell time on each channel sample. The time stamp has less than 1ms sample latency. DSM Analog input channels are fully differential with common-mode referenced to the GV airframe by 2k Ohms or less and offer common-mode rejection ratio (CMRR) greater than 80dB. Signal source drivers must have impedance less than 500 ohms and perform all necessary filtering.

An alternative, higher performance analog sampling module (GP-DACQ) can be requested that acquires four channels simultaneously at up to 100 Hz sample rate with advanced

filtering options and supports high impedance source drivers. Sampled data has 20-bit resolution and full-scale signal-to-noise ratio is greater than 110 dB.

Analog sampling is not available at GV wing pylon locations but can be made available within a wing pod with installation of a DSM.

Digital inputs: Digital data collection includes the acceptance of both serial and parallel data formats (5V, 24V). Pulse counting (5V, 10V) is also available. Data transfer rates are generally determined by the instrument and typically vary from 1 to 50Hz. ADS3 has the capability to sample and recording rates which are multiples of 1 Hz.

Industry standard asynchronous RS-232, RS-422, and RS-485 interfaces are provided in ADS3 with rates from 1200baud to 115 Kbaud. Serial channels are isolated at the DSM interface. ARINC-429 transmit and receive channels can be provided at both the standard high and low.

Note: The older-generation PMS 1-D and 2-D serial interfaces are no longer provided in the C-130 ADS3.

3.3.3 Network Description

The aircraft network is composed of a single gigabit-capable Ethernet subnet (192.168.84.x) that interconnects the server, DSMs, displays, other instruments, and user traffic via Cat-6 shielded twisted pair (STP) cable. Fiber optic cable for high bandwidth data transmission is also available and is currently installed in the wings and terminated in the cabin.

Network access is available at the eight SSDBs in the main cabin, and at the SSDBs in the baggage compartment and the nose. Figure 5.13 and Figure 5.14 show the locations of the main cabin SSDBs. Network wiring extends to all wing hardpoint locations.

A separate network links the ADS server to the SATCOM link for transmission to the ground.

3.3.4 Data Recording

Data sampled by ADS3 is recorded on redundant systems as “raw” data at sample rate and in the RAF ADS format. Data are stored on removable disk drives and/or other portable storage devices. A structured-query language (SQL) database is available for low-rate data storage/access by investigators who wish to have their data stored in a common database but not sampled through the ADS3. User data not going through a DSM may be sent to the database via the display network.

3.3.5 System Timing and Synchronization

GPS time-of-day is distributed to the DSMs and to the entire aircraft instrumentation suite primarily via network time protocol (NTP) via Ethernet but also as an IRIG-B timing word over STP wire. A master time server receives the GPS time-of-day information and provides these formats through an Ethernet connection. While the IRIG-B signal can be used by the C-130 ADS3 and by users to advance time and to identify the beginning of a one-second period, the 1 PPS time advancement method is considered

to be more reliable. Both the 1 PPS and IRIG-B signals are made available to users.

3.3.6 Data Display Overview

Real-time display of data on board the C-130 is provided by the NCAR Airborne Environment Research Observing System (AEROS) software package. Complete information about AEROS and instructions for use of the software are available in the *Aircraft Data Acquisition and Display System (ADADS) Reference Manual*. Briefly, the AEROS package operates on both Windows and Linux based computer systems and provides investigators with the capability to generate and view the following types of plots: timeseries, XversusY, track, skewT, ASClist, statistics, and sizedistribution. Only data streams recorded on the GVADS3 can be displayed on board using AEROS.

3.3.7 Data Broadcasts

A configurable ASC serial feed is provided to investigator equipment. The serial port output is typically set to 38,400baud with N81 for parity data and stop bits once per second. While the configuration of the serial feed changes on a per-project basis, the data stream format always consists of the following parameters in the order given: date, time, and selected and configured variables. Values included in the serial feed are separated by a space, and the line is terminated by a carriage return/line feed pair. A sample ASC serial feed stream is given below:

```
YY/MM/DD HH:MM:SS 1.234956e+008.325723e+02 ... . \r\n
```

An Ethernet broadcast of data that is identical in format to the ASC serial feed is also provided on board the GV. This broadcast consists of a UDP/IP packet sent once per second.

3.4 Satellite Data Communication Link

As outlined in Section 2.6.2 of Chapter 2, both Iridium and Inmarsat SATCOM systems are installed on the C-130. Both systems provide voice and fax communications and data transfer capabilities. The near-global coverage and high bandwidth (128kbps) characteristics of the Inmarsat system also provide the capability for controlling instruments and the C-130 ADS3 from the ground during flight.

The transmission of data products to and from the C-130 is limited by the available bandwidth of each system (2.4 kbps for the Iridium system and 128kbps for the Inmarsat system). In the case of the Inmarsat SATCOM system, the available bandwidth must be partitioned between voice communications, instrument control needs, time series and image data transfers, and text messaging in bi-directional mode. An on board computer controlled prioritization algorithm is configured for each C-130 project to provide control of Inmarsat bandwidth traffic flow and to ensure that critical data and messages are transmitted in a timely fashion. EOL personnel are currently still developing and implementing the software tools that will be required for utilization of the C-130 SATCOM systems for data transfer and instrumentation control. Further information on these utilities will be provided in this section as it becomes available.

Several tools are already available that will allow real-time web access to either direct field project participants, student groups or even common individuals with a casual interest in aviation research. Direct participants can communicate with onboard observers via text “chat” and the link can be used to transmit radar or satellite images, weather maps or sounding data to help provide in-flight guidance to modify research flight tracks and enable better sampling of targeted phenomena. Data access to in-situ measurements includes up to 20 variables and can include jpeg files taken from digital cameras documenting the flight environment. Outside groups or individuals can access some of this information via the EOL web site (<http://www.eol.ucar.edu/>) that uses an interface to Google Earth which adds the aircraft track to their global display technology. This web site provides a summary of all ongoing EOL field activities at any time.

3.5 Ground Support Computing

Depending on the region of operations and the location of the operations center, there will typically be a ground-based server that will be connected to a LAN where data will be processed post-flight and distributed to users who are connected to the LAN. In real time during a flight the ground server will also be gateway for two-way data communication between the aircraft and the ground. Often connections to a local ISP will be established and data (real-time and post flight) can be accessed from remote sites.

3.6 Data Products

Following each C-130 research flight, EOL personnel use the EOL/RAF Nimbus software package to process the collected data. Nimbus outputs data products in the network Common Data Form (netCDF) format. More information on netCDF is available on-line at <https://www.unidata.ucar.edu/software/netcdf/>. Preliminary data files generated following the completion of research flights are used by RAF personnel to perform initial quality checking of collected and derived data products. These preliminary files are also made available to investigators for initial review and analysis.

Data from investigator instruments that have been recorded on the C-130 ADS3 will be processed by Nimbus and released in the primary aircraft netCDF data file. Investigators who elect to record data on stand-alone data systems will be responsible for the processing and release of their own collected data products.

EOL has established a data policy governing the collection and release of data sets collected from EOL-supported atmospheric observing facilities, including the NSF/NCAR research aircraft. This policy can be viewed on-line at <https://www.eol.ucar.edu/content/eol-data-policy>. Investigators are strongly encouraged to review and become familiar with this policy in advance of the start of the designated field program.

Chapter 4 Performance

The Lockheed C-130Q is a pressurized, high-wing, turbo-propeller airplane which was designed as a military cargo aircraft. It is powered by four Allison T56-A-15 constant-speed, axial-flow, turbine engines that drive four-bladed, full-feathering, reversible-pitch turbo-propellers. Flight is approved in known icing conditions; however, certain external instrumentation installations may restrict operation in icing conditions.

Table 4.1 summarizes the basic performance characteristics of NSF/NCAR's Lockheed C-130Q Hercules aircraft.

Table 4.2 has some examples of expected maximum flight times.

The following considerations were used in constructing Table 4.1 and Table 4.2:

- 1. Standard day:** The standard day is defined as sea level, zero wind with a temperature of 15 °C and is used here to specify typical runway length and gross weight requirements. The NSF/NCAR Hercules is operated in accordance with the balanced field concept. This means that the airplane must have enough runway to accelerate to a specified speed (known as the critical engine failure speed), have an engine failure at that point, and either continue to takeoff successfully or stop on the remaining length of the runway. Furthermore, a minimum rate of climb on three engines must be assured.

There are numerous factors to be considered in determining the distance needed for takeoff or landing. The most significant of these are air temperature, pressure altitude and the gross weight of the airplane. The following examples illustrate the large increases in runway length required by changes in these factors.

The runway required for a fully loaded Hercules (155,000 lb) at sea level with zero wind and a temperature of 15 °C is 6,300 ft. At the same temperature, the Hercules would require 8,400 ft of runway and would be weight-limited to 145,000 lb when taking off from an airport elevation of 6,000 ft. Significant increases in temperature result in a substantial reduction in performance. At -7C, a fully loaded Hercules taking off from a sea level base would require 5,700 ft of runway. At 32C, all other conditions remaining the same, 7,200 ft of runway would be required. Each of the above examples assumes a dry runway. Takeoff weight may also be limited because of the requirement to maintain a specified climb rate after takeoff.

A combination of high airport elevation and high temperature results in a dramatic decline in an aircraft's takeoff performance. Normally, the only variable over which we have control is the gross weight of the airplane. Assuming that each crew member and all research equipment are essential to the mission, we are faced with reducing fuel load when a lower gross weight is necessary to

comply with the balanced runway requirement. The result, of course, is a reduction in range and/or the endurance of the aircraft.

2. **Visual flight rules (VFR):** VFR is briefly defined as a flight out of clouds and below 18,000 ft above mean sea level. A minimum of 45 minutes of reserve fuel is required to allow for diversions to alternate landing fields, should the primary destination airport be closed. Additional reserve fuel may be necessary depending on the distance to a suitable alternate.
3. **Instrument flight rules (IFR):** All flights at flight level 180 and above, as well as flight in clouds and in terminal control areas, must be conducted under instrument flight rules. This means that all phases of the flight must be conducted under the control of the appropriate air traffic control facility. The aircraft must have fuel to fly to the destination airport and then to a designated alternate airport, plus 45 minutes of reserve fuel.
4. **Cruising range:** The following example will illustrate how Table 4.1 can be used to calculate a rough estimate of the cruising range of the aircraft. Taking off from sea level with full fuel (62,000 lb) and climbing to 15,000 ft, 1,700 lb of fuel are used, and 44 nmi are flown in the 14 minutes required to climb. Considering 12,000 lb of fuel are required for standard operating reserve and IFR reserve, 52,940 lb of fuel are available for research ($62,000 \text{ lb} - 12,000 \text{ lb} - 1,700 \text{ lb} = 48,300 \text{ lb}$). At 15,000 ft and a research speed of 190 KIAS (240 KTAS) is obtained with an average fuel flow of 4,740 lb/hr. With 48,300 lb of fuel available for research, 10.2 hours of research can be flown. At a true airspeed of 240 kt, 2,445 nmi of research can be flown ($48,300 \text{ lb} @ 4,740 \text{ lb/hr} = 10.2 \text{ hours} \times 240 \text{ kt.} = 2,445 \text{ nmi}$). The 2,445 nmi of research, plus 44 nmi flown in the climb equals 2,489 nmi total range.

It should be noted that reserve fuel requirements may be considerably higher in areas with no suitable landing alternates. The result would be less fuel available for research and, therefore, less total range. In addition, descents and climbs for atmospheric soundings consume more fuel than cruising, and total range will be reduced. The values in Table 4.1 are for a standard atmosphere and a standard aircraft. They do not take into consideration parasitic drag of externally-mounted research equipment which will reduce performance.

**Table 4.1
PERFORMANCE SPECIFICATIONS (STANDARD DAY)
Lockheed Model C-130Q Hercules
Registration Number N130AR**

Category	Weight	
Maximum gross weight for takeoff	155,000 lb	
Maximum gross weight for landing	130,000 lb	
Maximum zero fuel weight	105,000 lb	
Operating weight (crew of 3, no fuel, basic instruments)	82,000 lb	
Fuel capacity	9,500 gallons (62,000 lb)	
Payload (crew and all equipment)	23,000 lb	13,000 lb (with full fuel)
Typical Runway Length Requirements		
Sea Level - ISA - 155,000 lb gross wt	6,300 ft	
5,000 ft elevation - ISA - 155,000 lb gross wt	8,500 ft	
Cruise Speeds		
Maximum distance	290 kt TAS (True Airspeed)	
Research (typical)	200-220 kt IAS (Indicated Airspeed)	
Slow flight	150 kt IAS	
Maximum speed (with instrument pods installed)	250 kt IAS	
Fuel Flow Average at Research Speed (190 kt Indicated Airspeed)		
@ 1,000 ft MSL, 194 kt TAS (True Airspeed)	5,300 lb/hr	
@ 5,000 ft MSL, 204 kt TAS	5,000 lb/hr	
@ 10,000 ft MSL, 220 kt TAS	4,870 lb/hr	
@ 15,000 ft MSL, 240 kt TAS	4,740 lb/hr	

@ 22,000 ft MSL, 274 kt TAS	4,400 lb/hr		
Maximum Range (With IFR Reserve and Full Fuel--No Wind)			
Altitude	Total Distance (nmi)	Total Flight Time (hr)	
< 1,000 ft	1,944	10.1	
5,000 ft	2,200	10.7	
10,000 ft	2,470	10.9	
15,000 ft	2,700	11.1	
20,000 ft	2,970	11.3	
25,000 ft	3,184	11.7	
Climbing Performance			
To	Time	Fuel	Distance to Climb (From Sea Level)
5,000 ft	3 min	500 lb	10 nmi
10,000 ft	8 min	1,000 lb	24 nmi
15,000 ft	14 min	1,700 lb	44 nmi
20,000 ft	24 min	2,700 lb	80 nmi
Cabin Altitude @ 28,000 ft Operating Altitude		5,000 ft	
Maximum Endurance (With IFR Reserve) @ Optimum Altitude		12.0 hr (Augmented flight crew required)	
Observer Stations Available			
Ferry flights		12	
Research flights		14	

**Table 4.2
FLIGHT PLANNING ESTIMATES
Lockheed Model C-130Q Hercules
Registration Number N130AR**

Assumptions:		
	Full fuel at takeoff	
	Transit to and from operating area at high altitude (> 18,000 ft)	
	IFR fuel reserves	
Distance from Base (nmi)	Research Duration at Low Altitude (hr)	Total Flight Time (hours)
940	3.8	10.7
700	5.1	10.3
500	6.4	10.2
300	7.7	10.1
150	8.6	10.0

Chapter 5 Flight Operations

5.1 Aircraft Certification Overview (public)

The NSF/NCAR C-130 is a retired military aircraft and does not have an airworthiness certificate. Technically it is operated as a United States government “State Aircraft” in the FAA “Public” category. This means that the aircraft does not have the same payload certification requirements as the GV. While not required to do so, EOL maintains and operates the aircraft under FAA Part 25 regulations and attempts to comply with basic military specifications for a Model C-130Q airframe. The avionics and communications equipment are suitably advanced enough to allow the conduct of international flight operations under the “State Aircraft” classification.

5.2 Crew Duty Limitations

Adequate rest for crew members is essential for the safe and efficient operations of NSF/NCAR aircraft in support of research programs. The restrictions in this section are the minima and maxima allowable. The 14-hour duty limit is intended for short, intensive operational periods and is not to be considered as a normal work day for NCAR flight crews. Investigators must be aware of other factors that flight crews must contend with, such as the fatiguing effects of continued IFR operation, extremes of temperature, complexity of mission requirements, and other variables that the pilot-in-command must consider in determining actual crew limits for any operation. During extensive research periods, proper rest becomes increasingly important, and when deemed necessary, the project pilot may elect to declare additional crew rest periods other than those listed below. Specific project flight schedules may necessitate additional staffing in order to meet the crew duty limitation requirements specified.

Single C-130Q crew duty limits, assuming ideal working conditions		
1.	Any 24-hour period	10 flight hrs
2.	Any consecutive 7 days	35 flight hrs
3.	Any 30-day period	110 flight hrs
4.	Consecutive working days	6 days
5.	Crew duty period	14 hrs
6.	Minimum crew rest period	12 hrs

Flight hours are calculated from block to block times, i.e., from the time the aircraft first moves under its own power for the purpose of flight to the moment it comes to a rest at the next point of landing. Crew duty periods start at the briefing time or when the crew is considered on alert and ends when the aircraft is shut down and secured. Days off will be scheduled at least 12 hours in advance, with the crew being relieved of all duties.

5.3 Operating Policies for Flight Planning

NCAR missions will be flown in accordance with FAA Regulations Subpart B, appropriate FLIP publications, ICAO procedures applicable to the host country, and NCAR directives.

5.3.1 Operations under Adverse Conditions

Adverse conditions include, but are not limited to, ceiling or visibility at or near minimums, marginal runway conditions, marginal approach aids, aircraft emergencies, severe turbulence, near maximum crosswind, unusual icing, terrain features that present an unusual hazard, and aircraft system malfunctions.

NCAR aircraft will not be operated into known or forecast weather conditions (icing included) that will exceed aircraft limitations. Aircraft limitations will be determined by the applicable flight manual.

NCAR aircraft will not be operated into areas of known or forecast thunderstorms unless radar is installed and operational or the weather forecast indicates that the flight can be conducted through the areas visually.

Final responsibility for the safe conduct of the mission rests with the Aircraft Commander. If in his/her judgment an unsafe condition exists, the mission will be delayed, canceled, or re-routed.

5.3.2 Maximum Cloud Reflectivity During NCAR Operations

Radar reflectivities of clouds have traditionally been utilized to establish rainfall rates that in turn are associated with turbulence and possible hail formations. Areas of high reflectivity gradients indicate steep rainfall gradients and are associated with turbulence. In order to maximize safety criteria for NCAR aircraft operations and still accomplish research objectives, maximum cloud reflectivity levels are hereby established. While this will not guarantee that NCAR research aircraft will not sustain damage the risk will be minimized.

Criteria – NCAR aircraft may penetrate, operate under, and operate within two nautical miles of a radar reflectivity echo of up to 40 dBz providing:

- a. A properly calibrated ground radar is operated by a skilled technician within the quantitative observing range of the radar.

- b. An RAF-approved, radar-trained scientist has access to the real-time display and is assigned to monitor and direct the aircraft operations. The radar scientist will maintain surveillance of the storm radar structure and voice contact with the plane at all times the aircraft is in the near-vicinity of storms, keeping cognizant of growth rates within storms, the fall rates of hail, and the limits of radar scan processes. The Aircraft Commander retains overall responsibility for safety of the aircraft and will remain in contact with radar scientist for all storm penetrations.
- c. In the absence of ground radar data, when only airborne radar is utilized, NCAR aircraft will not penetrate, operate under, or operate within three nautical miles of any storm cell having a radar echo that shows contouring reflectivity judged to be 39 dbz or greater.

5.3.3 Altitude Restrictions for NCAR Aircraft

Minimum stated altitudes apply unless a waiver has been obtained.

Except when necessary for takeoff or landing, no person may operate an aircraft below the following altitudes:

- a. Anywhere. An altitude allowing, if a power unit fails, an emergency landing without undue hazard to persons or property on the surface.
- b. Over congested areas. Over any congested area of a city, town, or settlement, or over any open-air assembly of persons, an altitude of 1,000 feet above the highest obstacle within a horizontal radius of 2,000 feet of the aircraft.
- c. Over other than congested areas. An altitude of 1,000 feet above the surface, except over Ocean water. In those cases, the aircraft may not be operated closer than 500 feet to any person, vessel, vehicle, or structure.
- d. Over Ocean water - VFR Conditions - An altitude of 100 feet above the surface for straight and level flight, and a minimum altitude of 300 feet for turning maneuvers exceeding bank angle of 5 degrees.
- e. Auto pilot engaged – Minimum altitude of 300 feet above the surface.

Added constraints for hours of Darkness or During Restrictive Visibility

- f. When operating under these conditions, over a flat surface such as the ocean or polar ice cap, a minimum altitude of 500 feet above the surface will be observed providing the radar altimeter is operational. Flight path excursions of short duration to a radar altitude of 300 feet are permissible.
- g. The above minimums have been established with near ideal conditions in mind. The Aircraft Commander must evaluate other factors such as turbulence, surface

conditions, fatigue, and duration of flight at low altitudes, etc. It may be necessary to raise these levels to what in his/her judgment, is appropriate for the existing conditions.

Note: These minimums do not apply to coupled approaches.

5.3.4 Use of Oxygen

Crewmembers will use oxygen as specified in the appropriate aircraft flight manual, FAR 91.32, or as follows:

- a. During daylight when the cabin pressure altitude is above 8,000 feet in excess of four hours, pilots and flight engineers 100% should use oxygen for 10 minutes of the last 45 minutes of the flight.
- b. Un-pressurized flights from 18,000 feet to 25,000 feet MSL require pre-flight de-nitrogenation breathing for 10 minutes. All crewmembers will breathe 100% oxygen from start of pre-breathing until the mission above 18,000 feet MSL has been completed and the aircraft has descended below 18,000 feet.
- c. Un-pressurized flights above 25,000 feet MSL will not be conducted.

5.3.5 Cancellation of IFR Flight Plans, Airborne

Flight plans should not be canceled during daylight hours whenever weather is unknown, reported as marginal, or when scud, haze, or other restrictions to visibility are known to exist. In these cases, maximum use of all available navigation facilities should be utilized to effect an instrument approach to the point of intended landing.

IFR flight plans should not be canceled during night operations until an instrument approach is initiated and then only if the terminal airfield is in sight and VFR weather conditions are reported and verified by the pilot.

The above policy is in no way intended to restrict the authority of the Aircraft Commander during in-flight emergencies or under any other condition wherein the cancellation of an IFR flight is fully at his/her discretion.

Note: For safety reasons the aircraft should have flight following until landing.

5.3.6 Weather Forecasts

The Aircraft Commander will ensure that the destination and alternate weather forecasts are obtained before reaching ETP on over-water missions. Weather forecasts will provide the Aircraft Commander with sufficient terminal weather information for diverting or continuing to destination.

5.3.7 Normal Procedures for Formation Flight

Close formation is only to calibrate and datum scientific instruments with other aircraft participating in scientific exercises.

Close formation is defined as when an aircraft is flying in close proximity to another aircraft in such a manner as to require the following aircraft to take all external visual references from the lead aircraft.

Close formation leading is defined as being totally responsible for all aspects of the safety, terrain clearance, positioning and handling for aircraft that are formatting in close proximity to the lead aircraft.

Close formation is only allowed with one other aircraft at any one time - formation lead and the forming aircraft (No.2).

The more restrictive regulations of the aircraft's state of registration, and airspace used, will always apply.

Aircraft shall not fly formation unless the aircraft commanders of the aircraft have agreed to do so.

5.4 Fitness Requirements

The C-130 will not normally be operated at less than normal cabin pressures so no special training or physical testing is typically required to fly on the C-130. However, thermal control of the cabin is limited in warm climates and the interior is loud in flight. Natural vibrations resulting from the propeller motion are also significant. Prolonged missions in excess of 6 hours are common and can be particularly fatiguing under the most adverse conditions. A special request to operate the aircraft at reduced cabin pressures, or un-pressurized, can be made for special operations but must be submitted at the time of the request for usage of the aircraft. If such a request is approved, special fitness testing may be required for all research crew. Flights above 14,000 feet internal cabin pressure require physiological training and altitude chamber testing. These training and testing procedures must be arranged well in advance of any flight program where such cabin altitudes will be required. Users considering such requests should discuss their requirements with the RAF prior to submission of the facility request.

All persons interested in participating in C-130 research flights are required to review the document "*Medical Information for Airborne Research*," which has been prepared for the RAF by Dr. Warren Jensen, FAA Senior Medical Examiner and Director of Aeromedical Research of the University of North Dakota. This document is provided in Appendix A of this handbook.

As of this writing, Federal requirements for investigators flying on U.S. government aircraft are undergoing review. Additional information about such requirements that may be applicable to the operation of the NSF/NCAR C-130 will be provided in future releases of this handbook.

5.5 Emergency Procedures

Aircraft emergencies will be handled in accordance with the FAA-approved *Airplane Flight Manual*, Rev. 15, November 13, 2000, and FAA-approved *GV Operating Manual*, Rev. 15, November 13, 2000, when applicable. In-flight emergencies involving onboard research systems or medical emergency situations will be evaluated by the in-flight RAF data system operator and will require flight crew notification as soon as is practical. The Pilot-In-Command (PIC) will be responsible for decisions concerning the flight plan after receiving notification of an emergency. All participants in C-130 research flights are responsible for promptly reporting any safety concerns (e.g., pressure leaks, smoke in the cabin, etc.) to the PIC.

5.6 Safety Training

RAF personnel have participated in special GV all-crew training courses that involve instruction in aircraft ditching safety procedures and cabin evacuation skill training. Some of the safety procedures learned by RAF staff members have been incorporated into the standard RAF C-130 safety training course for all flight participants.

All individuals who will be participating in C-130 research flights will be required to successfully complete an RAF safety and operations course before the start of the specific project. These courses are normally conducted at the RAF. Arrangements to conduct special classes in the field can be made with advance request, provided the aircraft is available. The class takes approximately one hour to complete. Topics covered include the following:

- A review of RAF standard operating procedures relevant to flight operations, with an emphasis on ground and airborne safety procedures;
- Training regarding emergency procedures to be followed onboard the aircraft;
- Training on the handling of hazardous materials;
- Briefing regarding project-specific safety issues;
- Instruction in the operation of aircraft systems (intercommunications system [ICS], lighting, seatbelts, emergency exits, etc.)

Additional training for investigators who will also be serving as mission scientists during specific projects are also provided (see Chapter 1, Section 1.2.3 of this handbook).

5.7 Security

At the time of this writing, the FAA and National Security Agency are considering the implementation of several measures that may require passenger screening. This may include a requirement for the performance of background checks. Any measures adopted by the U.S. government which will affect RAF flight operations will be outlined in future releases of this document.

Chapter 6 Investigator Equipment Packages

This chapter is intended to provide investigators with complete information about structural and electrical guidelines that must be followed as part of the design and construction of research equipment for the C-130. While the content of this chapter is intended to be as comprehensive as possible, investigators should also be aware that EOL personnel will assist investigators with meeting all of the requirements set forth herein for the C-130. Contact information for appropriate EOL personnel is provided throughout this chapter in order to facilitate communications between users and EOL staff. **New procedures imposing instrumentation flight testing prior to an instrument's inclusion in a research payload have been adopted. Check Chapter 8 for details.**

An accurate estimate of the weight and size of user equipment to be installed on the aircraft is a critically-important requirement in the initial request for aviation support. Estimated weights and sizes also must include any support equipment (e.g., gas cylinders, spares, tools, supplies) which are to be carried on the aircraft during ferry or research flights. RAF's feasibility evaluation of a program is based on this information. Any changes to the original proposal will require a reevaluation of the proposed flight profiles, and possibly require changes in the cabin layout, to comply with aircraft balance requirements. A sample cabin layout showing possible rack and seat configurations appears in Figure 6.1.

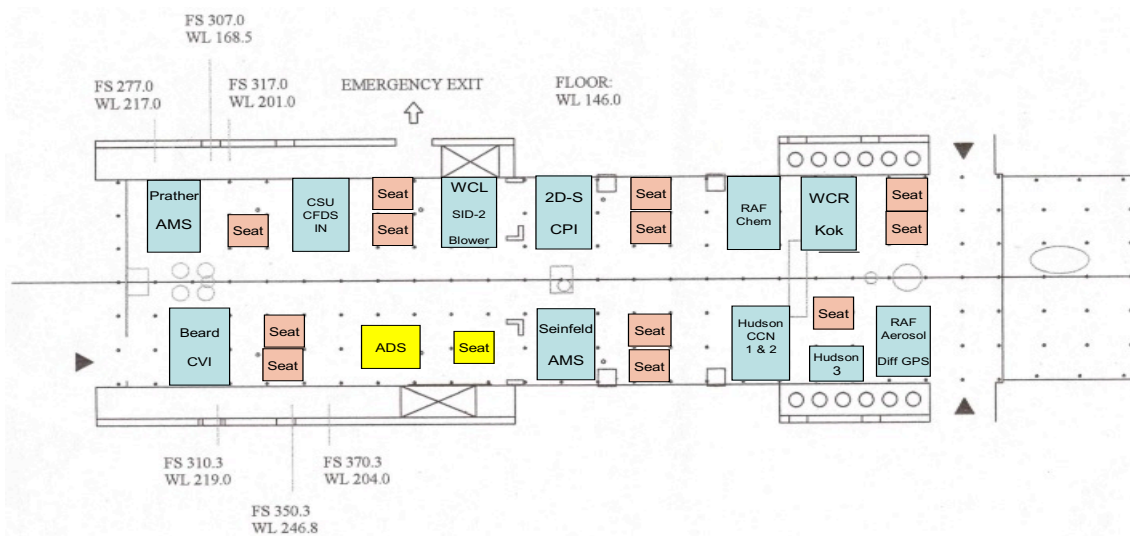

Figure 6.1 Typical Research Cabin Configuration

Prior to installation on the aircraft, all user equipment will be weighed and identified by an appropriate tag and entered in the instrumentation log book. Prior to departure, all spares, supplies and associated gear, including personal baggage, also will be weighed and properly marked. These actual weights will be used in the weight-and-balance calculations required for the safe operation of the aircraft. Strict compliance is mandatory. Any un-weighed and unmarked items will be removed from the aircraft.

6.1 Design Criteria

All equipment that attaches to or is used on the NSF/NCAR aircraft must conform to the following basic design load criteria: emergency landing conditions, in-flight lift and drag forces and gust loads--all acting independently. Emergency landing loads are defined as loading that occurs during other than a normal landing, such as a wheels-up landing or veering off the runway. Lift and drag forces are defined as those loads encountered during flight at maximum design airspeed and sea level conditions due to the shape and size of externally-mounted equipment. In-flight gust loads are defined as the loads resulting from turbulence. The following design load criteria are from Federal Aviation Administration or aircraft manufacturer-approved data and include appropriate safety factors.

All equipment, including racks, instruments, pallets, tie-downs, etc., and supporting structure that attaches to hard-points inside the aircraft cabin (the cabin being defined as that space occupied by personnel) must be designed for the emergency landing conditions listed in Table 6.1. The emergency landing condition loads are independent of the in-flight loads and must be calculated separately.

Table 6.1. Emergency Landing Criteria

Load Direction	Load Factor (Ultimate) Occupied Areas	Load Factor (Ultimate) Unoccupied Areas
Forward	9.0 g (9.0 x wt. of equip.)	3.0 g
Up	3.0 g (3.0 x wt. of equip.)	2.0 g
Down	6.0 g (6.0 x wt. of equip.)	4.5 g
Side	3.0 g (3.0 x wt. of equip.)	1.5 g

Aft 1.5 g (1.5 x wt. of equip.) 1.5 g

All externally-mounted equipment and supporting structure that attaches to external hard-points on the aircraft must be designed for the airspeed (lift and drag) loads and the in-flight gust loads. For the C-130 these criteria are:

Airspeed – 250 kias at sea level conditions
In Flight Gust Loads – 8.25 g down and 5.25 g up.

The Aeronautical Engineering Department of the RAF will assist in the interpretation of these criteria as well as provide guidance in the design or attachment of user-supplied equipment on the NSF/NCAR aircraft.

All equipment for pressurized aircraft (e.g., optical view ports, air sampling chambers, valves or lines) must maintain the pressure differential between cabin pressure on one side and outside ambient pressure on the other. It must be designed to a collapse or burst pressure of at least 1.1 kg/cm² (15.6 psi) for the C-130Q independent of other loads.

NOTE: *Due to the low ground clearance of the C-130 fuselage, an added maximum length limit will be imposed on all belly mounted equipment - regardless of the associated gust loads. No belly mounted equipment can extend more than 10” from the aircraft skin. It has been demonstrated that aerosol and gas sampling inlets of this length are still long enough to reach the free atmosphere outside the aircraft boundary layer even at the aft most sampling location (FS 682).*

6.2 Structural Considerations

This section sets forth the guidelines to be followed for the design, fabrication, and approval of investigator research equipment to be flown onboard the NSF/NCAR C-130. The design, modification, and installation of airborne research equipment is one of the more demanding and time consuming aspects of airborne research.

All equipment must also be designed or modified to attach to the various mounting points and instrument racks on the NSF/NCAR C-130. Properly securing all equipment and ensuring that the equipment loads can be reacted to by the aircraft is a mandated requirement to ensure the safety of each crew member and the safe operation of the aircraft. A detailed description of the aircraft mounting points is provided in Chapter 3 of this handbook.

Newly designed, commercially-purchased, and other equipment not designed for aircraft use must be evaluated for structural integrity and, if necessary, be modified or strengthened to comply with the criteria outlined in this section. Also, all equipment designed for aircraft use will be reviewed for conformity to design and installation

specifications. In addition to structural considerations, any wiring in user-supplied equipment must adhere to guidelines established and outlined herein.

Equipment designs that fail to comply with the guidelines of this handbook or hardware that fails to conform to the design documentation will not be installed on the aircraft until the deficiencies are corrected. In the event that the deficiencies cannot be corrected, the equipment will not be permitted on board the aircraft for flight research. RAF Aeronautical Engineering personnel will assist the user in understanding and complying with the requirements of this section.

6.2.1 Materials

Metallic

Aluminum is the preferred material for the fabrication of parts because of its good strength to weight ratio, formability and machineability, availability and cost. Of the numerous alloys available, it is generally best to select 2024, 6061, or 7075 aluminum alloys based upon previous aircraft industry usage and good availability. The following guidelines for aluminum alloy and temper selection should be considered:

- For sheet metal applications (material thickness < 0.125 inches) 2024-T3 clad sheet and 7075-T6 clad sheet are preferred. The advantage of the 2024-T3 clad sheet over the stronger 7075-T6 sheet is that 2024 can be formed in the T3 temper while 7075 material should be formed in the O temper and heat treated after all forming processes.
 - For plate material required for machined parts, 2124-T851 or 7075-T7351 should be used for their increased fatigue and fracture properties.
 - Extruded material should be 7075-T73 or -T76.
 - For lightly loaded structures or if welding is absolutely necessary, 6061 aluminum alloy should be used. Welded materials should be utilized in statically loaded structures only. If loading is repetitive or cyclic, strict quality control during fabrication and the development of on-going inspection requirements (x-ray, dye-penetrant) is necessary to ensure voids, inclusions, and incomplete fusion typical of welded structures to not adversely affect the strength and service life of the component. 6061 must be heat treated after welding in order to develop full strength capability. Material left in the as welded condition will be in the annealed state (O temper) with little strength in the heat-affected zone near the weld.

For machined fittings where aluminum provides insufficient strength or for welded structures, it is preferable to use low alloy steels or corrosion resisting (stainless steel, A286) materials. The 4130, 4140, and 4340 low alloy steels are commonly used and available in a variety of product forms. These steels do require corrosion prevention treatment and thus are not normally used in exterior applications on aircraft. 17-4PH, 15-5PH, and 17-7PH precipitation hardened stainless steels and A286 are commonly used corrosion resistant materials. These materials are strengthened by heat treatment and should not be used in the annealed condition. The 300 series stainless steels are austenitic stainless steels. They can be cold worked to provide additional strength and are readily formed without requiring additional finishing and heat treatment.

All material property data used in strength calculation should be from DOT/FAA/AR-MMPDS-01, Metallic Materials Properties Development and Standardization (formerly Mil-Hdbk-5H), or other acceptable data.

Non-Metallic

Commercial electronic components need not comply with these requirements. Additionally, small parts (such as knobs, handles, rollers, fasteners, clips, grommets, rub strips, pulleys, and small electrical parts) that would not contribute significantly to the propagation of a fire are exempted per Title 14, Code of Federal Regulations, Part 25, Appendix F, Part 1(a)(1)(v). Unique electronic components, wiring and cabling external to individual electronic boxes, and plumbing between different pieces of research equipment are expected to comply with this memo.

Materials that are flammable, produce smoke, or emit toxic fumes when exposed to a combustible or high-temperature environment should not be used in research equipment assemblies. The following non-metallic materials are acceptable for cable and wiring insulation and for supply and exhaust line plumbing:

- Teflon TFE (tetrafluorethylene)
- Teflon PFA (perfluoroalkoxy)
- Teflon FEP (fluorinated ethylene propylene)
- Teflon PTFE (polytetrafluoroethylene)
- Tefzel ETFE (ethylene & tetrafluoroethylene)
- Halar ECTFE (ethylene & monochlorotrifluoroethylene)
- Kynar PVDF (homopolymer of vinylidene fluoride)
- Silicone Rubber
- Polysulfone
- Hypalon CSPE (chlorosulfonated polyethylene)
- Neoprene (polychloroprene)
- Natural Rubber (NR isoprene)

The following materials are not acceptable for use in research systems to be carried aboard NSF/NCAR aircraft:

- Polyester
- Nylon
- Polyvinyl Chloride (PVC)
- Polyethylene (PE)
- Polypropylene
- Polyurethane
- Kapton (polyimide resin)

Experimenters are responsible for reviewing their drawings and parts lists to ensure non-acceptable materials are not specified for use in their system design. Non-metallic materials not listed in this memo must have data substantiating the acceptable use of the material aboard aircraft. If no such data exist, the experimenter will be required to

demonstrate compliance with Title 14, Code of Federal Regulations, Part 25.853(a). One method of showing compliance for materials in compartments occupied by crew and for electrical system components is detailed in Title 14, Code of Federal Regulations, Part 25, Appendix F, Part 1(a)(1)(v) and Title 14, Code of Federal Regulations, Part 25, Appendix F, Part 1(a)(3) respectively. NCAR RAF will supply copies of these applicable sections upon request. Alternate methods of showing compliance must be negotiated with NCAR RAF Engineering, Operations, and Safety. The experimenter should allow ample time for this process prior to anticipated participation in research programs.

NCAR RAF personnel will inspect experimenter packages prior to installation on the aircraft. Experimenters should be able to provide certification for materials used in their equipment assembly. Material certifications should be requested from the supplier when material is ordered. Failure to provide acceptable information or data could result in equipment rework prior to obtaining approval for installation aboard the aircraft.

Hazardous

Hazardous materials can be included in a C-130 research payload, but all such materials must be identified at the time of the initial facility request in order to allow adequate time for the RAF to review their impact on flight operations. The following equipment/materials require such a special review:

- Lasers
- RF Emitters
- Cryogenics (oxygen, hydrogen, methane, ethane, and ethylene are prohibited)
- Compressed Gases
- Toxic Gases (may require containment)
- Batteries
- Pressure Vessels/Systems
- Motors/Pumps (except for small fan units in commercial electronic equipment – 400 Hz motors rated explosion proof or totally enclosed non-ventilated are preferred; DC brush-type motors are generally not acceptable)
- Heaters (surfaces >130^o F require shielding and labeling)
- Power Distribution Equipment
- Radioactive Materials
- Flammable/Noxious Materials (PVC jacketed wire [except in commercial units] and cable or plumbing is not acceptable - Teflon based materials should be used; consult RAF Safety Committee concerning material acceptability)

The decision to permit hazardous materials and/or instruments to be used on board NSF/NCAR aircraft will be made by the RAF Safety Committee after a complete review

of the materials and equipment involved. The committee will ensure that the aircraft and the personnel on board are not subject to unreasonable hazards under conditions which can be expected during the conduct of the operation. The committee will specify safeguards, when appropriate. Researchers should prepare and submit safety documentation to the RAF Safety Committee and coordinate with RAF Project Management to ensure that appropriate approvals are obtained prior to the start of operations.

6.2.2 Fasteners

All fasteners should be aircraft quality hardware (to AN, MS, or NAS standards and specifications). Table 6.1 provides information on commonly used aircraft fasteners:

Designation	Fastener Description
Conventional Rivets MS20470AD MS20426AD NAS1097	Protruding Head Solid Rivet Flush, Full Size Head Flush, Reduced Head
HI-Loks HL18 HL19 HL70 HL20 HL21 HL86	Protruding Shear Head Pin Flush Shear Head Pin Shear Collar Protruding Tension Head Pin Flush Tension Head Pin Tension Collar
Bolts/Screws AN3-AN20 NAS6203- NAS6220 MS24694 NAS517 AN525 MS27039 NAS623	Hex Head Bolt (125 ksi) Hex Head Bolt (160 ksi) Flush Head, Phillips Drive (125 ksi) Flush Head, Phillips Drive (160 ksi) Washer Head, Phillips Drive Screw Pan Head, Phillips Drive (125 ksi) Pan Head, Phillips Drive (160 ksi)
Washers NAS1149 AN970	Plain Washer Large Area Flat Washer

Nuts	
MS21042	Hex Nut, Low Height, Self Lock (160 ksi tension)
MS21044	Hex Head, Full Height, Nylon Lock (125 ksi tension)
NAS1804	12 point, Full height (180 ksi tension)
MS21059	Floating Nutplate, Std Spacing
MS21075	Floating Nutplate, Mini Spacing
MS21061	Floating Nutplate, Std Spacing, One Lug
NAS1473	Self Sealing Nutplate, Std Spacing
NAS1474	Self Sealing Nutplate, Mini Spacing
Inserts	
MS21209	Locking Helical Coil Wire
MS51830	Screw Thread, Key Locked, Regular Duty (Keensert)
MS51831	Screw Thread, Key Locked, Heavy Duty (Keensert)
MS51832	Screw Thread, Key Locked, Extra Heavy Duty (Keensert)
Blind Fasteners	
NAS1669	Hex Head Blind Bolt (Jo-Bolt)
NAS1670	Flush Head Blind Bolt (Jo-Bolt)
M7885/2	Protruding Head Blind Rivet (Cherry-Max CR3213))
M7885/3	Flush Head Blind Rivet (Cherry Max CR3212)
M7885/13	Flush Shear Head Blind Rivet

Table 6.1. Aircraft-Quality Fasteners

6.2.3 Equipment Racks

The majority of equipment installed in the cabin of the C-130 will be mounted in standard racks designed by NCAR that attach to the floor of the aircraft. The racks are designed to accept standard nineteen inch wide rack mountable equipment. Mounting rails conforming to the universal spacing of EIA Standard RS-310 are provided on each side of the rack both forward and aft facing. There are two types of NCAR racks that can be made available for use.

Standard RAF Double Wide C-130 Racks

Figure 6.2 shows the dimensions of a standard, double-bay C-130 rack. The maximum equipment weight in the instrumentation rack is 408 kg (900 lbs total, 450 lbs per bay), and the maximum overturning moment is 206 kg-m (18,000 lb-in total, 9,000 in-lbs per bay). The moment arm is measured from the bottom of the rack to the center of gravity - **CG** - of the equipment. Asymmetrical loading of the rack bays will reduce the maximum allowable weight limit for the overall rack. A horizontal offset of the total rack CG by 3" reduces the total load limit to 355 kg (780 lbs). An offset of 6" reduces the total load limit to 320 kg (700 lbs). Attachment points are available on the top of the rack and equipment can be mounted in that location as long as the overturning moment for the rack remains within the allowable limit.

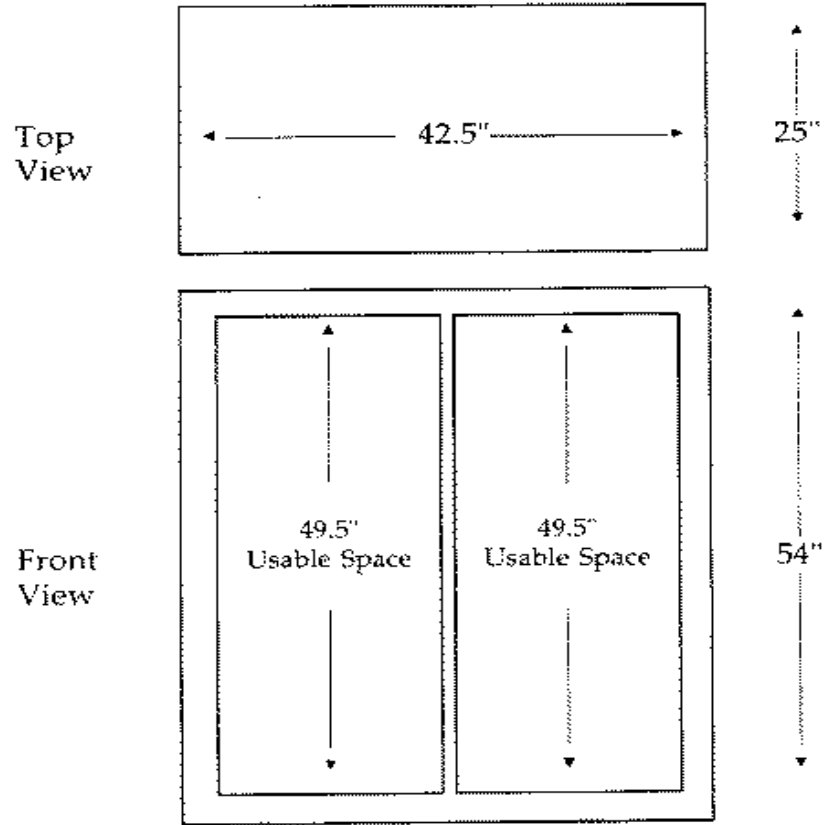

Figure 6.2. Standard C-130 Equipment Rack; each bay is 19" wide.

Heavy equipment cantilevered from the face of the rack must be supported by rails or trays. The following chart from the NASA DC-8 Airborne Laboratory Experimenters Handbook, June 2002, is also applicable for the NCAR C-130 rack (use High Rack sections):

Standard panel height (in.)	Low and Medium Rack			High Rack		
	M _{allow} (in.-lb)	W _{allow} Fwd/aft-mount (lb)		M _{allow} (in.-lb)	W _{allow} Fwd/aft-mount (lb)	
	case A	cases A and B	case C	case A	cases A and B	case C
3.5	73	23/35	38/63	123	53/53	92/129
5.25	84	35/52	50/80	185	79/79	118/155
7	124	46/70	61/98	245	105/105	144/181
8.75	163	58/87	73/115	305	132/132	171/208
10.5	244	70/105	85/133	365	158/158	197/234
12.25	2912	81/122	96/150	430	184/184	223/260
14	338	93/140	108/168	490	211/211	250/287
15.75				550	237/237	276/313
17.5				615	263/263	302/339
19.25				675	290/290	329/366
21				735	316/316	355/392
	△1	△1 △2 △4	△3 △4	△1	△1 △2 △5 △6	△3 △5 △6

Case D (figure A-3) requires engineering disposition/approval when equipment weight on tray exceeds 28 lb (Low/Medium Rack, aft-mounted) or 76 lbs (high rack, aft-mounted). Reduce these allowables by 1/2 if tray is fwd-mounted.

- △1 Case A (cantilevered)
- △2 Case B (cantilevered, supported on standard DC-8 light or heavy tray)
- △3 Case C (attached and constrained by standard DC-8 heavy tray)
- △4 Values based on 30 lb/in. flange allowable (fwd-mount) and 45 lb/in. flange allowable (aft-mount) in a 9-G forward loading condition
- △5 Values based on 101 lb/in. flange allowable (fwd- and aft-mount) in a 9-G forward loading condition
- △6 Component lateral CG displaced 25 percent left or right of equipment bay centerline

Standard RAF Single Bay GV Racks

The individual GV style racks are 50 inches high, 21.5 inches wide and 28 inches deep. There are 24U (42 inch) mounting rails on the forward and aft faces for standard 19 inch rack mountable equipment. The mounting rails are symmetrically centered vertically on the rack. The mounting faces of the rails are flush with the forward and aft faces of the rack. A 3/8 inch panel is attached to the top and bottom and can also be used for equipment mounting. These honeycomb panels require inserts to enable equipment mounting. There is 3.6 inches of clearance between the ends of the mounting rails and the inner surfaces of the panels. Figure 6.3 on the following page shows a standard cabin equipment rack.

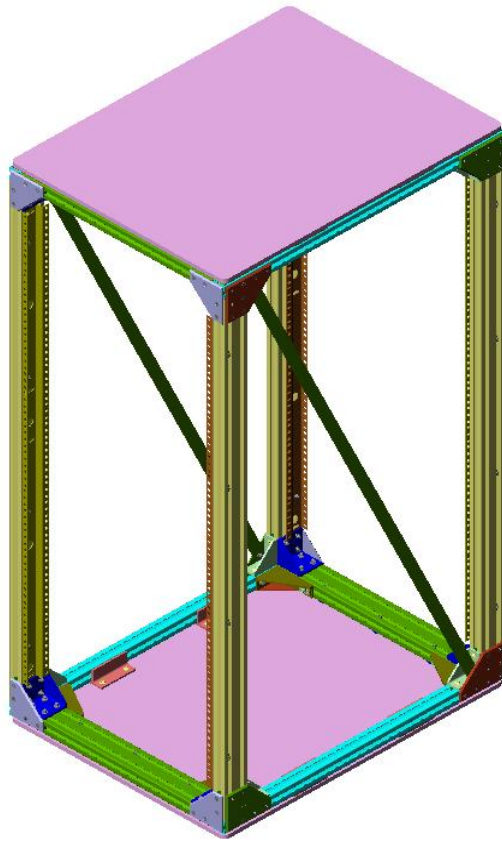

Figure 6.3. Standard GV Equipment Rack

The maximum allowable equipment weight is 350 pounds. The maximum allowable equipment overturning moment (measured from the bottom of the lower panel, i.e. the base of the rack) is 7,000 inch-pounds. Researchers should prepare a scaled layout of their rack configuration and determine:

- Individual component weight;
- Individual component panel height;
- Individual component center of gravity (cg) distance from panel;
- Total equipment weight (S component weights); and
- Total moment (S component weight x cg height from base)

Face mounted equipment weight and moment (weight x center of gravity distance from the mounting panel) must fall below the maximum allowable curves given in the following graphs:

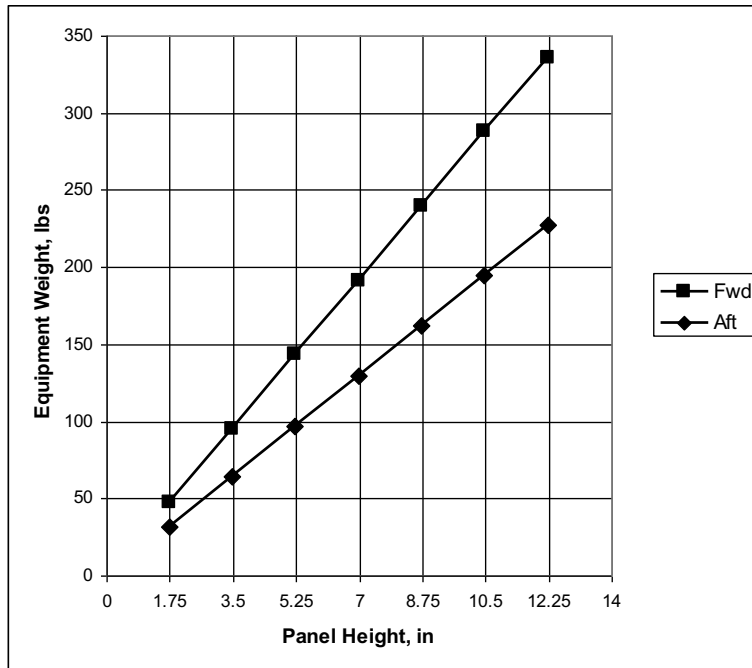

Figure 6.4. Allowable equipment weight for mounting to face chart.

For example, according to Figure 6.4, equipment weighing 75 pounds would require a 2U (3.75 inch) panel for forward face mounting or a 3U (5.25 inch) panel for aft face mounting.

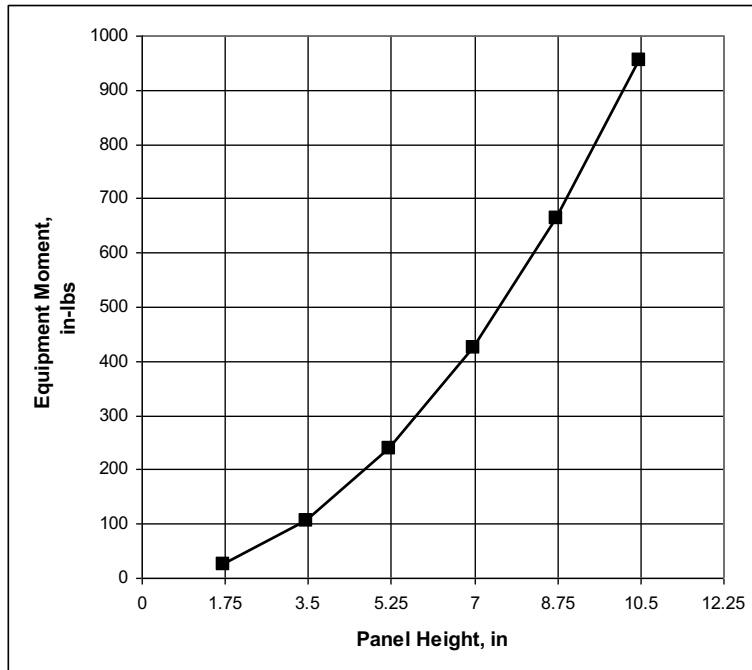

Figure 6.5. Allowable face-mounted equipment moment chart.

Per Figure 6.5, equipment weighing 50 pounds and 8 inches deep (center of gravity = $8 / 2 = 4$ inches from the mounting panel) would produce a moment at the face of 200 inch-pounds (Moment = $50 \times 4 = 200$ inch-pounds) and would require a 3U (5.25 inch) mounting panel height minimum.

For equipment that falls above these allowable curves, additional internal support and bracing (longitudinal mounting rails or trays) will be required. Two types of trays for supporting non-rack mountable and/or heavy equipment are available. Aeronautical Engineering can assist the researcher in determining the proper support requirements.

Modifications to standard equipment racks are not permitted under any circumstances. Stress analysis of the rack structure, track attachments, and floor structure is not required, except for nonstandard installations.

NOTE: Interface hardware is available to allow two GV style racks to be mounted side-by-side, mimicking the total racks space available in a standard Double Wide C-130 rack. These racks are available for purchase through EOL/DFS.

User Supplied Racks

User supplied racks and other nonstandard installations (optical benches, etc.), will require stress analysis of the support structure, equipment attachment locations, and floor attachments. Maximum equipment weights for the cabin floor cannot exceed any of the following parameters:

- 219 pounds per square foot uniformly distributed in the forward cabin

- 343 pounds per square foot in the aft cabin
- 45 pounds per square foot on the ramp

Floor tie down fittings are rated for either 10,000 lbs or 5,000 lbs static load, in any direction.

6.3 Electrical Considerations

The following sections provide guidance to investigators for the electrical design of equipment intended for flight on board the NSF/NCAR GV. Electrical components within a research system can be the source of potentially hazardous situations in flight, the latter of which can include interference with basic aircraft systems, fire, shock, etc. Correspondingly, care must be taken during the equipment selection and wiring processes in order to minimize these risks.

6.3.1 Wiring Guidelines

Instrument builders must demonstrate that all user-fabricated interconnecting wire (e.g., from component to component, component to aircraft interface, etc.) complies with the requisite FAA requirements. Wire and cable types referred to here include any special types of wire, such as high-speed data wire, fiber optic cable, coax cable, etc. NCAR recommends that Teflon jacketed wire be used by investigators to construct special purpose wire and cable as such wire is known to meet flammability testing requirements. Polyvinyl chloride (PVC) wiring is not permitted for these applications without specific approval due to hazards associated with smoke and noxious fumes generated when such wiring burns. Commercial power strips are not acceptable, unless they have been modified to incorporate an aircraft approved circuit breaker and aircraft approved wire.

In the case of existing research equipment (defined here as equipment that has been flown on a research aircraft prior to January 1, 2005), the FAA Denver Aircraft Certification Office (ACO) has agreed that demonstration of compliance with electrical wire insulation flammability requirements (via burn testing and/or the submission of Forms 8110-3) will not be required provided that the following conditions are met:

- Wiring and associated electrical components are enclosed in a metal box suitable for containing a fire;
- The box is positioned such that it is clearly visible in the aircraft cabin; and
- Power to the box can be easily disconnected via a main power switch or an aircraft grade circuit breaker.

Investigators should note, however, that FAA compliance will be required for any modifications made to pre-existing (previously flown) research equipment. Additionally, it must be emphasized that compliance will continue to be required for all user-fabricated interconnecting wiring (including the wire, tubing, chafe protection materials, etc.) that is external to a metal enclosure and that is located inside the GV cabin.

In general, workmanship in the wiring of user-supplied equipment shall be of the highest quality possible. Some examples of unacceptable workmanship include: insufficiently-soldered joints, cold solder joints, poor or inadequate insulation, and improper crimping. User-supplied equipment with substandard wiring will be repaired by the user and re-inspected by the RAF prior to installation on the aircraft.

6.3.2 Batteries

It is permissible for research equipment to make use of small numbers of AA, AAA or D-type alkaline or nickel-cadmium (Ni-Cd) batteries without special approval from the RAF. All other usage of batteries on the aircraft requires advance approval by RAF flight safety personnel. The RAF strongly recommends that investigators select batteries with benign chemistries that are hermetically sealed. The following battery types are recommended:

- Alkaline
- Silver-zinc (Ag-Zn)
- Nickel-cadmium (Ni-Cd)
- Sealed lead acid

When designing equipment that requires batteries, investigators should take into account the following considerations when making a battery selection:

- Battery assembly (see discussion above);
- Battery shipment into the field, including packaging requirements, safety issues, applicable shipping restrictions, battery shelf life limitations, and final disposal (hazardous material) requirements.

Specific RAF approval of battery use is required for batteries that make use of hazardous materials and/or in cases where the number of batteries to be used exceeds six (6). Additionally, investigators should be aware that approval of battery usage is dependent upon the total aircraft configuration and the assessed risk for all potential hazardous items on board the GV. Approval will be given for a specific GV project configuration or flight. Investigators are required to submit complete vendor specifications data sheets to the RAF Safety Committee for review prior to installation of the batteries and associated instrumentation on the aircraft.

6.3.3 Uninterruptible Power Supply (UPS)

Investigators should note that batteries within UPSs selected for use on the C-130 must meet the requirements set forth in Section 5.3.2 above. Additionally, UPS input power cords must meet the wiring practice specifications detailed in Section 5.3.1 of this chapter. All UPS units intended for use on the C-130 will be subject to inspection by RAF personnel.

6.3.4 Electric Motors

Early consultation with RAF personnel during the electric motor selection process is essential and will help to avoid problems at the time of equipment installation. Each

electric motor to be used on board the C-130 must be reviewed and approved by the RAF Safety Committee (genzling@ucar.edu). For all equipment that utilize high energy rotor devices (i.e., pumps), investigators will need to provide confirmation to the RAF that failure of the rotor(s) at high operating speeds will not adversely affect aircraft systems, structures, or occupants. Advisory Circular 25-22, Section 25.1461, *Equipment Containing High Energy Rotors*, details the procedures and requirements that must be met to ensure satisfactory operation of high energy rotor devices. Investigators can view and download this Advisory Circular online at http://www.gofir.com/fars/advisory_circulars/frame2.htm. Confirmation provided to the RAF can be in the form of a written manufacturer's statement, results of rotor device testing at an outside test facility, or results generated from investigator-conducted device testing witnessed by an NCAR engineer.

The usage of 400 Hz motors is preferred, as such motors do not introduce starting transient loads on the 60 Hz power converters employed on the aircraft. Larger motors (e.g. those used in vacuum pumps) must be protected by a thermal overload device. Additionally, single-phase motors must be equipped with solid state switches to inhibit arcing at the contacts during start up. In the absence of arc suppressors, motors must be shown to be spark free during operation.

Motors that are rated as explosion-proof or totally enclosed and non-ventilated are recommended for use on the C-130. However, many fractional horsepower, AC permanent split-capacitor motors are acceptable for use on the aircraft depending on their application and location and if they are proven to be safe in the event of motor failure. Large DC brush-type motors are generally not acceptable due to electrical arcing that occurs at the brushes.

6.3.5 Heaters

All heaters to be used on the C-130 must be reviewed by the RAF to ensure that electrical safety requirements are met, that proper circuit protection devices are used, and that any high temperature, exposed surfaces that might serve as ignition points for flammable gases or that may cause injury to flight personnel are identified. Exposed surfaces with temperatures above 54° C (130° F) are generally considered safety hazards and must be surrounded by adequate shielding and be labeled with caution signs.

6.3.6 High Voltage

Following guidance of Advisory Circular AC 25-10 (i) Guidance for installation of Miscellaneous, Non-required Electrical Instrumentation, "Because of the possibility of airplane decompression, a means must be provided for either automatic removal of power from all components containing CRT's or the installation of a barometric switch for each component using a CRT, unless the high voltage circuits and components have been shown to be free of arcing under appropriate environmental tests specified in RTCA DO-160B dated July 1984, or equivalent tests receiving prior approval by the FAA."

High Voltage is considered to be any piece of equipment using high voltage, 1000 volts or higher and with a current draw of more than 1.0 amp, used inside and/or outside the cabin.

With the advent of flat panel technology, display CRT's have become obsolete, other instruments may use some form of a CRT and they would need to comply. Consequently, any instrument using high voltage, a Lidar may be an example, will be required to automatically remove power from the high voltage source if decompression is a possibility. Other acceptable means are to prove that there is no arcing potential or enclose the high voltage section, wiring and associated electrical components in a metal box suitable for containing a fire. Some forms of potting/conformal coating may be acceptable if the materials are proven to pass the 25.853(a). Investigators can choose to remove the power from only the high voltage section of the instrument or the whole instrument. Typically, the barometric switch is used to control a relay to remove power. They are relatively small and fairly economical, more so than enclosing in a certified metal box. This would be up to the instrument builder to determine which way to go.

6.4 Data Recoding & Interface Capabilities

Information on the C-130 data acquisition and display system, available data interfaces and on board networks, and data and time broadcasts is provided in Chapter 2 of this handbook. Users are also referred to the *Aircraft Data Acquisition and Display System (ADADS) Reference Manual* for complete information on the aircraft's data recording and display capabilities.

6.5 Airflow Modeling Data & Availability

The RAF has the capability to examine the flow fields around key sections of the aircraft which can aid Users in preparing instrumentation for integration to the various external hard points on the fuselage and wings. Questions about available air flow and particle trajectory data products should be directed to the RAF Science and Instrumentation Group Lead and/or RAF Aeronautical Engineer.

Below is a summary of the air flow and particle trajectory data products that EOL has in its possession:

- Streamlines generated from the aircraft environmental outflow valve located on the forward right side of the aircraft;
- Particle concentration factors, concentration ratios, and accelerations on a vertical plane at the wing hard points for particle sizes of 20, 100, and 1000 microns;
- Particle concentration factors, concentration ratios, and accelerations on vertical (BL 3) and horizontal (WL 100, 145) planes through the fuselage for particle sizes of 20, 100 and 1000 microns;

- Boundary layer thickness along streamlines generated over the fuselage from the tip of the C-130 nose to the empennage. Except for deviations around protrusions (e.g., main gear fairing), the boundary layer thickness follows the basic rule of thumb of one inch of depth increase per each 100 inches of fuselage length (with fuselage length measured from the tip of the C-130 radome);
- Velocity magnitude contour plots, streamline plots, and velocity vector plots with the locations the same as those detailed in bullets 2 and 3, above; and
- Locations of supersonic regions at mach 0.77 and an aircraft angle of attack (AOA) of 2°.

Chapter 7 NCAR/EOL Standard Instrumentation Overview

The NSF/NCAR C-130 aircraft comes equipped with a package of standard instrumentation that flies on all C-130 research missions. The measurements made by these sensors form the core of any research program and provide the information necessary to place the aircraft in space and time while characterizing the basic “state” of the local environment. Figure 7.1 provides an external diagram of the C-130 documenting the configuration of these sensors on the aircraft. Data from all of these systems are recorded on the C-130 airborne data system (ADS) and can be displayed onboard, in real time, via the network of display stations.

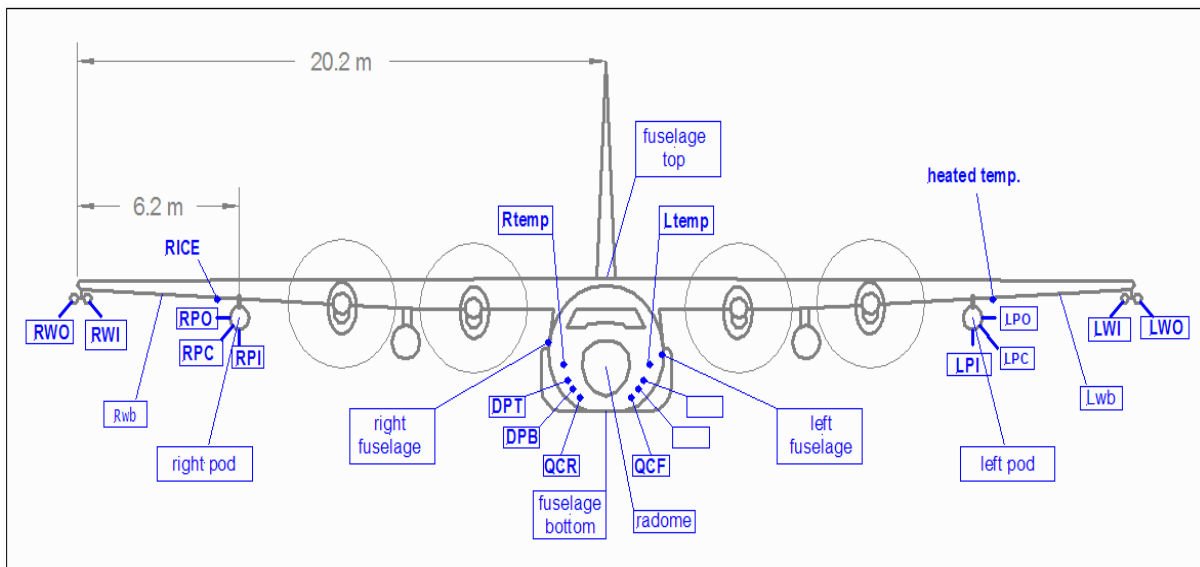

Figure 7.1 External Instrumentation Configuration of the C-130

Descriptions of the various types of sensors available as part of the standard package and those instruments that can be requested can be found at <https://www.eol.ucar.edu/airborne-instrumentation>.

Chapter 8 Feasibility & Instrumentation Integration Procedures

8.1 Instrument Certification and Approval

New instruments still under development are often included in requested research payloads. Field deployments have very specific deadlines and it is difficult to fully assess the airworthiness, functionality, and availability of these systems on such a time line (see Figure 8.1 for the typical time line of field project certification, upload, test flight and deployment, applicable to both the GV and C-130).

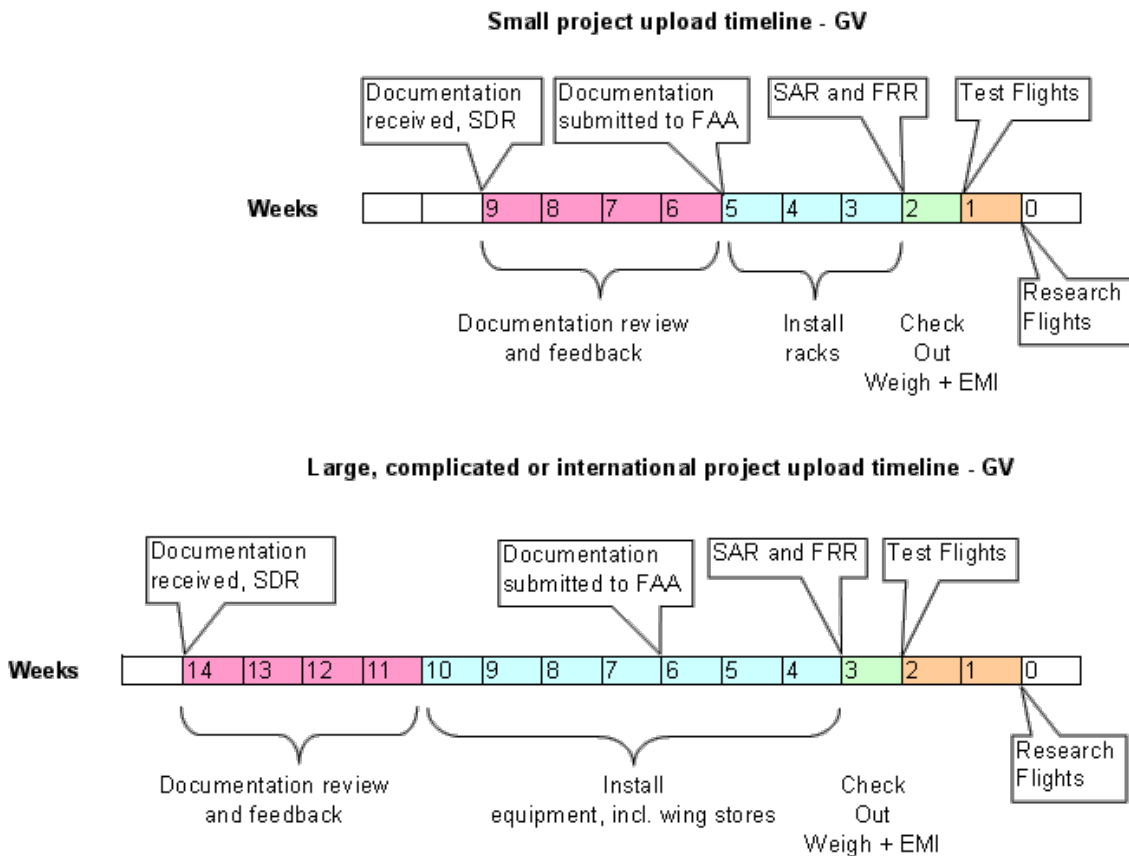

Figure 8.1: Typical time line for field project documentation, certification and review processes.

As discussed in Section 8.3 below, special arrangements need to be made to certify and “pre”-test these instruments prior to their inclusion in an approved research payload.

8.2 Project lifecycle reviews and payload certification

In preparation for project upload, several reviews will take place. They are: System Definition Review (SDR), System Acceptance Review (SAR) and Flight Readiness Review (FRR).

8.2.1 SDR

The SDR is to be held about a month prior to the beginning of project upload. The purpose of the SDR is to assess the status of documentation and instrument readiness for project installation with sufficient time to correct omissions and mistakes in documentations. (For equipment flown previously on the C-130 the documentation is needed only if the equipment has since changed). Participants in the SDR are RAF staff in consultation with the lead instrument and project PIs.

The next two milestones will take place one week before the first planned test flight. At this point the installations of equipment into the aircraft should be completed.

8.2.2 SAR

The purpose of the SAR is to assess the state of measurements from each instrument as installed on the aircraft. Instrument PIs will be asked to comment on measurements, data logging, communication with other systems, etc. and essentially provide an overview of the measurement quality at the time of the SAR. Participants in the SAR include RAF staff, instrument PIs, and the lead experiment PI.

8.2.3 FRR

The FRR will determine the airworthiness of the payload and will also be held one week prior to the first flight. The lead RAF aeronautical engineer will go through instrument installation one-by-one, and ask the RAF group heads (maintenance, technicians and pilots) if all required information (structural, materials, electrical, etc.) have been provided by the instrument PI. Instrument PIs do not participate in the FRR.

These reviews are not "pass-fail" exams but rather they are a formalized way of assessing the project preparedness status at several critical stages in the lead up to the project launch. We stress that the installations should essentially be done prior to the SAR and the FRR, and that the week between these reviews and the first test flight should only be used for minor instrument tune-ups, calibrations, etc.

Results of all reviews will be summarized and distributed to the project participants via e-mail.

8.2.4 EMI Test and safety briefing

In addition, three activities need to take place before the first test flight: the airplane must be weighed, electromagnetic interference (EMI) test conducted, and all persons flying on the aircraft must attend a safety briefing. Attending an RAF safety briefing for an earlier project does not count: safety briefings are mandatory before each project.

8.3 New Instruments

New instruments that have never flown on any aircraft before must successfully complete a flight test sequence prior to approval for use on a field deployment. Such testing must be done to insure both the airworthiness and functionality of the instrument. PI's will be asked to denote which instruments are "required" to meet their scientific goals. "Required" sensors must complete this process at least three months prior the scheduled start of the payload integration. "Clones" of previously flown instruments will be exempted from this requirement on a case-by-case basis depending on a review of any documented differences between the two systems. Key factors that will be evaluated are: non-metallic materials; power consumption; and wiring. Sensors considered to be "optional" to the scientific goals of the experiment may delay testing until the project specific, pre-deployment flight tests ***with the clear understanding that a failure to perform satisfactorily could result in their removal from the payload prior to the field deployment.*** With the agreement of both the PI's and the RAF, an optional system that fails to meet the flight test standards could be flown on a test basis during the field deployment.

G-V: Participation on any flight test program on this platform requires that the instrument pass through the FAA certification process. Details on this process, including material & power/wiring constraints and design & fabrication documentation requirements can be found on the RAF web site: (<https://www.eol.ucar.edu/node/22>) under the "NSF/NCAR G-V (HIAPER)" heading.

C-130: For this category only, the basic requirements on materials and power/wiring constraints will be the same as the GV. No formal FAA certification is required, but documentation on key system components must still be submitted to the RAF on the certification schedule outlined in the certification material above. However, it is highly recommended that newly designed instruments to be flown on the C-130 comply with the full set of requirements for the GV. This will ensure their future compatibility with the GV.

8.4 Instruments Previously Flown

Instruments that have successfully been flown on one of the NCAR aircraft, or any other manned research aircraft in the international fleet, will typically be exempt from the pre-upload functionality flight testing requirement. However, systems that have undergone modification since their last deployment must be re-evaluated to establish the extent of the changes. If the modifications are deemed to be significant (i.e. replacement of a primary component with new technology), some form of additional flight testing may be required. Key factors that will be evaluated are: non-metallic materials; power consumption; and wiring.

G-V: Participation in any field program on this platform requires that the instrument pass through the FAA certification process. Details on this process, including material & power/wiring constraints and design & fabrication documentation schedules can be

found on the RAF web site: (<https://www.eol.ucar.edu/node/22>) under the “NSF/NCAR G-V (HIAPER)” heading. Certification on another platform or by another regulatory agency on a similar platform (like the DLR “HALO” G-550) does **NOT** transfer between platforms, but the basic documentation should be similar. The certification process, which is payload specific and not instrument or rack specific, must be completed prior to the start of sensor integration on the G-V. Therefore, ***all certification documentation must be submitted to the RAF engineering staff 2 months prior to the scheduled upload. Failure to submit the required documentation by this deadline will result in the removal of this instrument from the research payload.*** Instrument providers may be required to rebuild structural and electrical components or replace unsuitable materials as part of the certification process. Project specific payload flight testing will be conducted just prior to deployment to the field site.

C-130: Participation in any program on this platform only requires notification of key integration and support needs and successful completion of a structural, materials and power/wiring review by RAF staff. There are no formal documentation deadlines beyond the initial submission of the facility request, although some basic documentation will be needed for the facility records. Project specific payload flight testing will be conducted just prior to deployment to the field site.

8.5 Feasibility Review of Proposed Campaigns

The process for requesting one of the NSF/NCAR aircraft platforms in support of a scientific field project and the deadlines for filing such a request can be found on the EOL web site (<http://www.eol.ucar.edu/deployment/request-info/forms/request-forms-for-nsf-lower-atmospheric-observing-facilities>). As per standard practice, information on all user-supplied equipment to be included in a specific research payload must be provided as part of the EDO as well as the formal request. Any special instrument integration requirements should be noted at this time. Prior to a scientific review by NSF and the OFAP panel, EOL conducts a very specific “feasibility review” to determine if the research payload is supportable and if the requested flight operations can be supported in a safe manner.

In the EDO and Facility Request feasibility review processes, field program payload requests will be evaluated on the basis of “required” versus “optional” sensors. During the interactive communications prior to the submission of a formal request for support, PI’s will be asked to denote which instruments are “required” to meet the scientific goals of their project. If a New Instrument (EOL or user-supplied sensor) is included in the list of required instrumentation for an EDO and this instrument has not completed the functionality flight testing the RAF will communicate with the PIs and the NSF to determine a course of action that may include:

- Delaying the research project until the flight and performance testing of the required instrument is completed,
- Investigating the possibility of involving an equivalent instrument with existing performance history,

- Investigating whether or not the instrument is justified as "required" for the field project.

If an EOL supplied New Instrument is included in a Facility Request as "required" or "essential" and has not completed the functionality flight testing by the time of the OFAP meeting discussing the request, the request will be deemed "Unfeasible". In the event that any User supplied New Instrument on the required list cannot meet the GV certification and safety requirements, RAF will inform NSF that the sensor is not "airworthy" and recommend that the field project be re-evaluated for feasibility and scientific merit with that sensor omitted from the research payload. Failure of an "optional" sensor to comply with the stated requirements would result in the removal of that system from the overall research payload without impact on the overall project feasibility.

8.6 Flight Test Opportunities

A key component of ensuring that new instrumentation is ready for research deployments without compromising the compressed project deployment timelines will be the inclusion of annual flight test programs into the RAF schedule. Scheduled flight test opportunities are open to all NSF supported instrument developers so that they can comply with the new requirements on New Instrument flight testing. Space is limited and will be allocated based on system readiness and on association with an NSF funded research project. EOL plans to continue with some form of annual flight test program (based on the example of the IDEAS programs). Depending on community need and available intervals in the RAF deployment schedule, more than one test program may be scheduled in a particular year. The platform chosen for any specific flight test program (GV or C-130) will vary, depending upon availability. For more information on how to participate in one of these flight test programs contact the RAF Facility Manager.

Chapter 9 Insurance – Liability Coverage, Bodily Injury, Property Damage

Aircraft operations conducted by UCAR/NCAR personnel are insured – to the extent of the policy coverage – for legal liability arising from third-party claims.

This coverage extends to instrumentation installed on the aircraft as part of NSF-approved flight operations. UCAR also is insured for legal liability involving operation of motor vehicles and general liability hazards.

All UCAR/NCAR staff members are covered by the UCAR Travel Accident Policy as stated in the UCAR Benefits Manual.

Non-UCAR staff should check with their home institution for workers compensation coverage, medical and life insurance coverage, and for possible insurance exceptions related to flying in a public aircraft operation.

Appendix A Medical Information for Airborne Research

Research Aviation Facility (RAF)

Medical Information for Airborne Research

Prepared with the assistance of Dr. Warren Jensen, FAA Senior Medical Examiner, Director of Aeromedical Research, University of North Dakota, (UCAR OGC Review August 03)

The following information should assist you in identifying potential problems that could interfere with your ability to participate in research in NCAR/NSF aircraft. The information contained herein is in no way designed to be comprehensive. If you have any concerns about your ability to fly on NCAR/NSF aircraft, please consult your physician.

There is a possibility that you may be in situations that would require you to take care of yourself including such activities as evacuating the aircraft, dealing with turbulence, opening doors, and wearing an oxygen mask. It is important to identify conditions that may interfere with your performance of such duties. If you feel you cannot perform any duty or feel there may be an issue that could affect any aspect of your participation, do not continue without first consulting your physician.

The following medical conditions and policies could affect your safety and ability to participate in research in NCAR/NSF aircraft. Should you feel that you possess any of the conditions listed below or if you are unable to comply with any of the policies listed, you should NOT participate in NCAR/NSF aircraft at this time.

1. Any medical condition that would not allow you to continuously walk for 10 minutes or up two flights of stairs.
2. Any medical condition that would inhibit your ability to be able to lift 40 pounds.
3. Interruption of your normal activities because of difficulty breathing, conditions such as asthma, or other lung/heart problems that interrupt your normal activities.
4. Ear or sinus problems when flying.
5. Motion sickness when flying.
6. Problems with hearing and speech that would interfere with the ability give and receive instructions in a room with moderate background noise.
7. Taking any medication that gives side effects of drowsiness or difficulty in maintaining alertness.
8. Any condition, illnesses or injuries that would interfere with the ability to perform duties on research flights and to evacuate the aircraft if necessary.
9. Any condition, illnesses or injuries that might require the assistance of a RAF crewmember.
10. RAF policy limits flying for 24 hours after immunizations, dental work, and SCUBA diving.
11. Pregnancy beyond the 20th week as well as any other concerns related to the health of a pregnant mother or baby.
12. RAF policy prohibits carrying any person suffering effects from alcohol consumption on a flight, regardless of when it was consumed, and also restricts flight if alcohol has been consumed within 8 hours prior to flight.
13. Symptoms of upset stomach, gas, or diarrhea prior to flight

Appendix B Approved Wiring and Non-Wire Materials

August 10, 2012

RAF recommends using MIL-W-22759 wire for all Single Conductor Wire applications as listed in Advisory Circular AC 43.13-1B Table 11-11 “Open Wiring”, specifically MIL-W-22759/16. These wire types meet FAA flammability requirements. Wires listed in Table 11-12 “Protected Wiring” of the same Advisory Circular are NOT acceptable for use outside of a metal enclosure.

Multiconductor Cable

Type	Part Number	Manufacturer	ID	Supplier
STP-12	12-TE-1925(2)STJ	Thermax	677F-1	All Cable
STP-12	CA 1888	Cal Wire	57449	California Wire
STT-12	12-TE-1925(3)STJ	Thermax	677F-1C	All Cable
STT-12	CME4-03-STW-1219	Astro Ind	75866	Electrospec
STT-14	14-TE-1927(3)STJ	Thermax	677F-2	All Cable
STT-14	CME4-03-STW-1419	Astro Ind	75867	Electrospec
STP-16	16-TE-1929(2)STJ	Thermax	59633	ElectroSpec
STP-16	CME4-02-STW-1619	Astro Ind	58575	ElectroSpec
STT-16	16-TE-1929(3)STJ	Thermax	677F-3	All Cable
STT-16	CME4-03-STW-1619	Astro Ind	75860	Electrospec
STT-18	18-TE-1930(3) STJ	Thermax	677F-9B	All Cable
STT-18	CME4-03-STW-1819	Astro Ind	75868	Electrospec
STP-18	CME4-02-STW-1819	Astro Ind	75857	Electrospec
STP-18	18-TE-1930(2)STJ	Thermax	81173	Electrospec
STP-20	20-TE-1932(2)STJ	Thermax	677F-4	All Cable
STP-20	CME4-02-STW-2019	Astro Ind	75858	Electrospec
STT-20	20-TE-1932(3)STJ	Thermax	90408	All Cable
STT-20	CME4-03-STW-2019	Astro Ind	90408	Electrospec
STP-22	22-TE-1934(2)STJ	Thermax	89728	All Cable
STP-22	CME4-02-STW-2219	Astro Ind	75859	Electrospec
STT-22	22-TE-1934(3)STJ	Thermax	57449	All Cable
STT-22	CME4-03-STW-2219	Astro Ind	75862	Electrospec
STT-24	24-TE-1936(3)SXE	Thermax	677F-6	All Cable
STT-24	24-TE-1936(3)STJ	Thermax	75865	All Cable
STT-24	CME4-03-STW-2419	Astro Ind	75861	Electrospec
STQ-24	24-TE-1936(4)STJ	Thermax	677F-7	All Cable
STQ-24	CME4-04-STW-2419	Astro Ind	75863	Electrospec
ST5-24	24-TE-1936(5)STJ	Thermax	81173	Electrospec
STQ-26	26-TE-1938(4)STJ	Thermax	677F-2C	All Cable
STQ-26	CME4-04-STW-2619	Astro Ind	75864	Electrospec
TWX	M17/176-00002	Thermax	677F-14	All Cable
HEAD1	YQ-27540	Belden	677F-16	Buck Research
HSDQ	89728	Belden	677F-17	Belden

Multi conductor cable	342239-39/C	Electronics cable Specialist	87901	Electronics cable Specialist
PMS Cable	6548PA	Belden	90355	Electrospec

Special Wire

Type	Part Number	Manufacturer	ID	Supplier
C50	S44191	PIC	6870	PIC
C50	COAX316SON #RL0458338	Thermax	57436	All Wire
C50	S44193	PIC	6753	PIC
C50	S33141	PIC	2831	PIC
C50	S22089	PIC	7404	PIC
NET	E50824	PIC	6753	PIC
USB	USB2422	PIC	7161	PIC
FW(Fire-wire)	FAWM226C-008	Northwire	91904	Northwire
FW(Fire-wire)	FAWM226C-003	Northwire	91905	Northwire
Firewire	912406	Electronic Cable Spec	9972	Electro Spec
Fiber optic	S696T-02F-62X	DRAKA	9710	Glenair
Fiber optic	S696T-01-62X	DRAKA	9710	Glenair
Fiber optic	S696T-16-62X	DRAKA	9710	Glenair
Thermocouple	5TC-TT-T-24-36	Omega Engineering	87819	Omega Engineering
Thermocouple	WTT-6-60-TT	Omega Engineering	88169	Omega Engineering
Thermocouple	EI1110202/SA1-T-72	Omega Engineering	88169	Omega Engineering
Arinc Cable	422202	Carlisle	92196	ECS

Flat Ribbon Cable (Used in DSM)

Type	Part Number	Manufacturer	ID	Supplier
10 Pin conductors	F2807S-10-050-55	TEMP-FLEX Cable	677F-3C	Electro Spec.
20 Pin conductors	F2807S-20-050-55	TEMP-FLEX Cable	57449	Electro Spec.
26 Pin conductors	F3007S-26-025-85	TEMP-FLEX Cable	72286	Electro Spec
40 Pin conductors	F2807S-40-050-55	TEMP-FLEX Cable	57449	Electro Spec.
44 Pin conductors	F2807S-44-0394-55	TEMP-FLEX Cable	72286	Electro Spec
50 Pin conductors	F2807S-50-050-55	TEMP-FLEX Cable	677F-30B	Electro Spec.

Coaxial Cable

Gauge	Type	Part Number	Manufacturer	ID	Supplier
18 AWG	RG-142 B/U	M17/158/00001	BELDEN	677F-31	BELDEN

20 AWG		S88207	PIC WIRE	9668	PIC WIRE & CABLE
26 AWG	75-OHM	Part#V76261	PIC WIRE	9626	PIC WIRE&CABLE

Approved and Tested Non-Wire Materials

Tubing	Part Number	Manufacturer	ID	Supplier
1/4" Comp	SYNFLEX 1300-04403	SAINT-GOBAIN	677F-5C	SAINT-GOBIN
3/8" Comp	SYNFLEX 1300-06603	SAINT GOBAIN	677F-6C	SAINT-GOBIN
3/8" OD Conductive Silicone	3001788 #1851 (TSI #) VC-781 Solid Carbon-filled	VANGUARD	677F-7C	TSI
1/2" OD Conductive Silicone	3001789 (TSI #) VC-781 Solid Carbon-filled	VANGUARD	9800	TSI
1/8" OD Clear	22UHP .063X .125	AMETEK	677F-10C	AMETEK
1/8" OD Black	104-0125031-OTC	Parker Hannifin Corp	77918	Metron Tech. Central
1/4" OD Clear	TSFP5 .250125	SAINT-GOBAIN	677F-9C	SAINT-GOBIN
1/4" OD TEFLON, 22P	22P.156X.250	AMETEK	56210	AMETEK
1/4" OD Black	104-0250047-OTC	Parker Hannifin Corp	77919	Metron Tech. Central
3/8" OD TEFLON	UHP22.250X.375F	AMETEK	59056	AMETEK
3/8" OD Clear	UHP22.313X.375	AMETEK	91060	AMETEK
3/8" OD Clear	UHP22.250X.375H	AMETEK	72509	AMETEK
3/16" OD Clear	22P.125X.187	AMETEK	84286	VQS
3/16" OD Semi-Clear	5239K11	McMaster-Carr	89761	McMaster-Carr
5/16" OD Clear	AAC000012-CP	SAINT-GOBAIN	9800	SAINT-GOBAIN
5/16" OD Clear	AAC00025	SAINT-GOBAIN	151937-06	SAINT-GOBAIN
1/2" OD Clear	UAT500-062	AZTECH	72889	AZTECH CONTROL
ARMAFLEX Foam Insulator	APT03834	ARMACELL	75233	EJ Bartells or Armacell
DEGUSSA Foam Insulator	½" ROHACELL-110S	N/A	10032	SCION CORE SYS.
Insulation material OffWhite	207-782-7011	InsulSAFE Textiles, Inc	89308	InsulSAFE Textiles

Wire Protection	Part Number	Manufacturer	ID	Supplier
3/8" Black Sleeve	HTN0.38TB	TECHFLEX	677F-8C	TECHFLEX
1/2" Black Sleeve	HTN0.50TB	TECHFLEX	57449	TECHFLEX
1/4" Left Cut, Spiral Wrap	TSWTF-1/4-NT-L	PARKER	91785	PORT PLASTIC, INC.

1/4" Right Cut, Spiral Wrap	TSWTF-1/4-NT-R	PARKER	91786	PORT PLASTIC, INC.
3/8" Right Cut, Spiral Wrap	TSWTF-3/8-NT-R	PARKER	91784	PORT PLASTIC, INC.
3/8" Left Cut, Spiral Wrap	TSWTF-3/8-NT-L	PARKER	91787	PORT PLASTIC, INC.
1/2" Left Cut, Spiral Wrap	TSWTF-1/2-NT-L	PARKER	91783	PORT PLASTIC, INC.
1/2" Right Cut, Spiral Wrap	TSWTF-1/2-NT-R	PARKER	91788	PORT PLASTIC, INC.

Other	Part Number	Manufacturer	ID	Supplier
.125" Plastic Phenolic	FBGS.125N	ACCURATE	72813	ACCURATE PLAST.
Phenolic Insulator strip	8796K42	ARAMID	76178	McMaster Carr
Insulated Duo-Tape Low Watt Density	AWH-WWW-XXXDL	Amptek Company	V220288	Amptek Company
Insulated Duo-Tape Medium Watt Density	AWH-WWW-XXXDM	Amptek Company	V220287	Amptek Company
Insulated Duo-tape Low Watt Density	A401-NCAR0311-20	Amptek Company	90775	Amptek Company
Insulated Duo-tape Low Watt Density	A401-NCAR0311-21	Amptek Company	90775	Amptek Company
Insulsafe Textiles	P-100	ARAMID	V220289	Mc Master Carr
Arimid Strip 1" Wide	8796K72	Mc Master Carr	V219907	Mc Master Carr
Aerogel Pyrogel XT Insulation	PG XT 5MM-5	Pacor Inc	V219907	Pacor Inc
Spaceloft White Insulation	SL 5MM-XX	Pacor Inc	90859	Pacor Inc
Ultem 1000 Arimid Strip	Ultem 1000	Colorado Plastic	H219907	Colorado Plastic Prod
MP Graphite/Poly Foam 45 ILD 1/2"	Lot #Z574-595-MP45	Skandia Inc	91237	Skandia, Inc
MP Graphite/Poly Foam 65 ILD 1/2"	Lot #12660-MP65	Skandia Inc	91237	Skandia, Inc
MP Graphite/Poly Foam 45 ILD 1/2"	Lot #W1132-1142-MP45	Skandia Inc	91237	Skandia, Inc
Clear Plastic .125"	PCBFRCLSH00125 PALSUN FR	Professional Plastic	92077	Professional Plastics, Inc

Single Conductor Wire

Type	Part Number	Manufacturer	ID	Supplier
10 AWG RED	M16878/4 BMG-9	Thermax	677F-3B	All Cable
10 AWG WHT	M16878/4 BMG-2	Thermax	677F-11B	All Cable

10 AWG BLK	M16878/4 BMG-0	Thermax	677F-21B	All Cable
12 AWG WHT	M16878/4 BLE-2	Thermax	677F-12 B	All Cable
12 AWG RED	M16878/4 BLE-9	Thermax	677F-4 B	All Cable
12 GAW BLK	M16878/4 BLE-0	Thermax	677F-22 B	All Cable
14 AWG WHT	M16878/4 BKE-2	Thermax	677F-13 B	All Cable
14 AWG RED	M16878/4 BKE-9	Thermax	677F-2B	All Cable
14 AWG BLK	M16878/4 BKE-0	Thermax	677F-23 B	All Cable
16 AWG WHT	M16878/4 BJE-9	Thermax	677F-8	All Cable
16 AWG BLK	M16878/4 BJE-0	Thermax	677F-9	All Cable
16 AWG RED	M16878/4 BJE-2	Thermax	677F-14 B	All Cable
18 AWG RED	M16878/4 BHE-9	Thermax	677F-1B	All Cable
18 AWG WHT	M16878/4 BHE-2	Thermax	677F-15 B	All Cable
18 AWG BLK	M16878/4 BHE-0	Thermax	677F-24 B	All Cable
20 AWG WHT	M16878/4 BGE-9	Thermax	677F-10	All Cable
20 AWG BLK	M16878/4 BGE-0	Thermax	677F-11	All Cable
20 AWG RED	M16878/4 BGE-2	Thermax	677F-16 B	All Cable
22 AWG WHT	M16878/4 BFE-9	Thermax	677F-12	All Cable
22 AWG BLK	M16878/4 BFE-0	Thermax	677F-13	All Cable
22 AWG BLUE	M16878/4 BFE-6	Thermax	677F-28 B	All Cable
22 AWG RED	M16878/4-BFE-2	Thermax	57401	All Cable
22 AWG ORG	M16878/4-BFE-3	Thermax	57401	All Cable
22 AWG YEL	M16878/4 BFE-4	Thermax	57401	All Cable
22 AWG BRWN	M16878/4 BFE-1	Thermax	677F-29 B	All Cable
24 AWG WHT	M16878/4 BEE-9	Thermax	677F-5B	All Cable
24 AWG RED	M16878/4 BEE-2	Thermax	677F-17 B	All Cable
24 AWG BLK	M16878/4 BEE-0	Thermax	677F-25 B	All Cable
26 AWG WHT	M16878/4 BDE-9	Thermax	677F-6B	All Cable
26 AWG RED	M16878/4 BDB-2	Thermax	677F-18 B	All Cable
26 AWG BLK	M16878/4 BDB-0	Thermax	677F-26 B	All Cable
28 AWG RED	M16878/4 BCB-2	Thermax	677F-19 B	All Cable
30 AWG WHT	M16878/4 BBB-9	Thermax	677F-8B	All Cable
30 AWG RED	M16878/4 BBB-2	Thermax	677F-20 B	All Cable
30 AWG BLK	M16878/4 BBB-0	Thermax	677F-27 B	All Cable
22 AWG BLK	178-8679	Teledyne Reynolds	73141	

Obsolete Part Numbers

wire protection	part number	manufacturer	id	supplier
1/4" Left Cut, Spiral Wrap	401-025030-N00000L	PARKER	677F-11C	PORT PLASTIC, INC.
1/4" Right Cut, Spiral Wrap	401-0250030-N00000R	PARKER	90710	PORT PLASTIC, INC.
3/8" Right Cut, Spiral Wrap	401-0375030-N00000R	PARKER	677F-12C	PORT PLASTIC, INC.

3/8" Left Cut, Spiral Wrap	401-0375030-N00000L	PARKER	677F-13C	PORT PLASTIC, INC.
1/2" Left Cut, Spiral Wrap	401-0500030-N00000L	PARKER	677F-14C	PORT PLASTIC, INC.

Wire Type Abbreviations:

STP	- Shielded Twisted Pair
STT	- Shielded Twisted Triple
STQ	- Shielded Twisted Quad
TWX	- Twinax Cable
HEAD1	- Special Dew Point Cable
HSDQ	- High-Speed Data Quad
C50	- 50-Ohm Coaxial Cable
NET	- GigaBit Network Cable